

Driving Performance and Digital Billboards

FINAL REPORT

Prepared for:

Foundation for Outdoor Advertising Research and Education

By:

Suzanne E. Lee

Melinda J. McElheny

and

Ronald Gibbons



**TRANSPORTATION
INSTITUTE**

Center for Automotive Safety Research

March 22, 2007

TABLE OF CONTENTS

TABLE OF FIGURES	3
TABLE OF TABLES	5
ABSTRACT	6
EXECUTIVE SUMMARY	7
INTRODUCTION	11
REVIEW OF PREVIOUS RESEARCH	12
METHOD.....	19
SELECTION OF CITY	19
DIGITAL BILLBOARDS	19
EXPERIMENTAL DESIGN	19
<i>Independent Variables</i>	20
<i>Dependent Variables</i>	23
SELECTION OF DEPENDENT VARIABLES BASED ON PREVIOUS DRIVING STUDIES	24
<i>Measures of Visual Demand</i>	24
<i>Search and Scan Patterns</i>	24
<i>Mirror Glance Duration</i>	25
<i>Velocity</i>	25
<i>Lateral Position</i>	25
PARTICIPANTS	26
ROUTE AND EQUIPMENT	27
<i>Route</i>	27
<i>Vehicle</i>	31
<i>Data Collection System</i>	31
PROCEDURE	35
<i>Participant Recruitment and Screening</i>	35
<i>Experimental Protocol</i>	35
DATA REDUCTION	38
<i>Analyst Training</i>	38
<i>Software</i>	38
<i>Procedure</i>	39
<i>Event Identification</i>	39
<i>Eyeglance Analysis</i>	39
<i>Final Reduced Data Set</i>	40
<i>Statistical Analysis</i>	40
NIGHTTIME STUDY	41

RESULTS.....	44
POST-DRIVE QUESTIONNAIRE – DAYTIME RESULTS.....	44
<i>Demographics Overview</i>	44
<i>Route Familiarity</i>	45
<i>Overview of What Drivers Noticed</i>	46
POST-DRIVE QUESTIONNAIRE – NIGHTTIME RESULTS.....	49
<i>Age</i>	49
<i>Route Familiarity</i>	50
<i>Attention Getters</i>	50
<i>Most Memorable</i>	51
DRIVING PERFORMANCE RESULTS – DAYTIME.....	52
<i>Event Type</i>	52
<i>Other findings</i>	63
DRIVING PERFORMANCE RESULTS – NIGHTTIME.....	64
<i>Event Type</i>	64
NIGHTTIME LUMINANCE MEASURES.....	68
COMPARISONS TO THE CHARLOTTE STUDY	71
CONCLUSIONS.....	73
REFERENCES	74
APPENDICES.....	77
APPENDIX A: INITIAL PARTICIPANT TELEPHONE SCREENING FORM.....	77
APPENDIX B: INFORMED CONSENT FORM.....	80
APPENDIX C: HEALTH SCREENING QUESTIONNAIRE	85
APPENDIX D: POST DRIVE-QUESTIONNAIRE.....	87

TABLE OF FIGURES

FIGURE 1. ASSIGNMENT OF PARTICIPANTS TO EXPERIMENTAL CONDITIONS.....	20
FIGURE 2. MAP ILLUSTRATING DIGITAL BILLBOARDS (BLACK), CONVENTIONAL BILLBOARDS (RED), COMPARISON SITES (AQUA BLUE), AND BASELINE SITES (BLUE).....	23
FIGURE 3: NEWSPAPER ADVERTISEMENT THAT APPEARED IN THE CLEVELAND PLAIN DEALER.....	26
FIGURE 4. EXPERIMENTER SEATED IN EXPERIMENTAL VEHICLE.....	27
FIGURE 5. MAP OF 50-MILE DAYTIME LOOP ROUTE IN CLEVELAND, OHIO.	28
FIGURE 6. DIRECTIONS MOUNTED ON DASHBOARD OF VEHICLE (THIS PICTURE IS FROM A PREVIOUS EXPERIMENT WHICH USED THE SAME PROTOCOL AND VEHICLE TYPE).	30
FIGURE 7. EXPERIMENTAL VEHICLE, 2002 CHEVROLET MALIBU.....	31
FIGURE 8. FORWARD FACING CAMERAS MOUNTED BEHIND THE CENTER REAR VIEW MIRROR.....	32
FIGURE 9. DRIVER FACE CAMERA, MOUNTED NEAR THE LEFT A-PILLAR.	32
FIGURE 10. DRIVER FACE CAMERA MOUNTED ABOVE REAR VIEW MIRROR.....	33
33	
FIGURE 11. DIAGRAM OF SIMULTANEOUS PRESENTATION OF FOUR CAMERA VIEWS.	33
FIGURE 12. DATA ACQUISITION SYSTEM LOCATED IN TRUNK OF VEHICLE.	34
FIGURE 13. COMPONENTS OF THE DATA COLLECTION SYSTEM.	34
FIGURE 14. MAP ILLUSTRATING NIGHTTIME ROUTE WITH DIGITAL BILLBOARDS (BLACK), CONVENTIONAL BILLBOARDS (RED), COMPARISON SITES (AQUA BLUE), AND BASELINE SITES (BLUE).....	42
FIGURE 15. TOP DAYTIME ATTENTION GETTERS (TOP NINE OF EIGHTEEN POSSIBLE).....	47
FIGURE 16. TOP NIGHTTIME ATTENTION GETTERS (TOP NINE OF EIGHTEEN POSSIBLE).....	51
FIGURE 17. PERCENT EYES-ON-ROAD TIME FOR THE FOUR EVENT TYPES. (COMPARISON EVENTS WERE SIGNIFICANTLY LOWER THAN THE OTHER THREE EVENT TYPES, WHICH DID NOT DIFFER FROM ONE ANOTHER). ..	53
FIGURE 18. MEAN NUMBER OF GLANCES TO ANY LOCATION DURING AN EVENT. (THERE WERE NO SIGNIFICANT DIFFERENCES BETWEEN EVENT TYPES.)	54
FIGURE 19. MEAN NUMBER OF LEFT FORWARD GLANCES FOR EVENTS ON THE LEFT SIDE OF THE ROAD. (THERE WERE NO SIGNIFICANT DIFFERENCES BETWEEN EVENT TYPES.).....	55
FIGURE 20. MEAN NUMBER OF RIGHT FORWARD GLANCES FOR EVENTS ON THE RIGHT SIDE OF THE ROAD. (NONE OF THE OBSERVED DIFFERENCES WERE SIGNIFICANT.)	56
FIGURE 21. MEAN SINGLE GLANCE TIME FOR LEFT FORWARD GLANCES FOR EVENTS ON THE LEFT SIDE OF THE ROAD. (DATA POINTS WITH A SHARED LETTER DO NOT DIFFER SIGNIFICANTLY FROM ONE ANOTHER.)	57

FIGURE 22. MEAN SINGLE GLANCE TIME FOR RIGHT FORWARD GLANCES FOR EVENTS ON THE RIGHT SIDE OF THE ROAD. (DATA POINTS WITH A SHARED LETTER DO NOT DIFFER SIGNIFICANTLY FROM ONE ANOTHER.).....	58
FIGURE 23. TAILS ANALYSIS FOR THE DISTRIBUTION OF GLANCE DURATION, (METHOD DESCRIBED IN HORREY AND WICKENS, 2007).	59
FIGURE 24. MEAN SINGLE GLANCE TIME FOR GLANCES IN THE DIRECTION OF EVENTS. (DATA POINTS WITH A SHARED LETTER DO NOT DIFFER SIGNIFICANTLY FROM ONE ANOTHER.)	60
FIGURE 25. STANDARD DEVIATION OF SPEED BY EVENT, IN MILES PER HOUR. (DATA POINTS WITH A SHARED LETTER DO NOT DIFFER SIGNIFICANTLY FROM ONE ANOTHER.)	61
FIGURE 26. STANDARD DEVIATION OF SPEED BY EVENT FOR EVENTS OCCURRING ON INTERSTATES, IN MILES PER HOUR. (NONE OF THE OBSERVED DIFFERENCES WAS SIGNIFICANT.)	62
FIGURE 27. STANDARD DEVIATION OF LANE POSITION BY EVENT, IN INCHES. (NONE OF THE OBSERVED DIFFERENCES WAS SIGNIFICANT.)	63
FIGURE 28. EYES-ON-ROAD PERCENT BY EVENT TYPE FOR THE NIGHTTIME EXPLORATORY STUDY.....	65
FIGURE 29. OVERALL GLANCE FREQUENCY BY EVENT TYPE FOR THE NIGHTTIME EXPLORATORY STUDY.	65
FIGURE 30. MEAN GLANCE TIME FOR GLANCES IN THE DIRECTION OF AN EVENT FOR THE NIGHTTIME EXPLORATORY STUDY.	66
FIGURE 31. MEAN NUMBER OF GLANCES IN THE DIRECTION OF AN EVENT FOR THE NIGHTTIME EXPLORATORY STUDY.	66
FIGURE 32. SPEED MAINTENANCE AS MEASURED BY THE STANDARD DEVIATION OF SPEED BY EVENT FOR THE NIGHTTIME EXPLORATORY STUDY.....	67
FIGURE 33. LANE KEEPING AS MEASURED BY THE STANDARD DEVIATION OF LANE POSITION BY EVENT FOR THE NIGHTTIME EXPLORATORY STUDY.....	68
FIGURE 34. BRACKET FOR RADIANT IMAGING CCD PHOTOMETER.	69
FIGURE 35. RADIANT IMAGING CCD PHOTOMETER IN POSITION FOR MEASUREMENTS, WITH EXPERIMENTER MAKING FINAL ADJUSTMENTS.....	69
FIGURE 36. AVERAGE LUMINANCE OF THE FOUR EVENT TYPES, IN CANDELAS PER METER SQUARED.	70

TABLE OF TABLES

TABLE 1. INDEPENDENT VARIABLES.	20
TABLE 2. EVENT TYPES INDICATING DESCRIPTION, SIDE OF THE ROAD, LATITUDE, LONGITUDE, AND SPECIFIC SITE LOCATION INFORMATION.....	22
TABLE 3. DIRECTIONS FOR 50-MILE DAYTIME ROUTE IN CLEVELAND, OH.....	29
TABLE 4. DIRECTIONS FOR 1.5-MILE PRACTICE ROUTE IN INDEPENDENCE, OHIO.	30
TABLE 5. ORDER OF PARTICIPATION (SHOWN BY AGE AND GENDER).	36
TABLE 6. NIGHTTIME DRIVING DIRECTIONS.....	41
TABLE 7. NIGHTTIME ORDER OF PARTICIPATION.	42
TABLE 8. SUMMARY OF DEMOGRAPHIC RESULTS FOR ALL DAYTIME PARTICIPANTS.	45
TABLE 9. ROUTE SEGMENT FAMILIARITY FOR ALL DAYTIME PARTICIPANTS.	46
TABLE 10. NUMBER AND PERCENT OF COMMENTS FOR DAYTIME PARTICIPANTS FOR THE QUESTION: “WHAT WAS MOST MEMORABLE ABOUT THE DRIVE? FOR EXAMPLE, WERE THERE ANY OBJECTS THAT STOOD OUT?”.....	47
TABLE 11. NUMBER AND PERCENT OF COMMENTS FOR DAYTIME PARTICIPANTS IN RESPONSE TO THE QUESTION: “DOES ANYTHING ABOUT OTHER DRIVERS BOTHER YOU? IF SO, PLEASE BRIEFLY DESCRIBE.”	48
TABLE 12. NUMBER AND PERCENT OF COMMENTS FOR DAYTIME PARTICIPANTS IN RESPONSE TO THE QUESTION: “WHAT OTHER ACTIVITIES DO YOU TYPICALLY ENGAGE IN WHILE DRIVING?”	49
TABLE 13. SUMMARY OF DEMOGRAPHIC RESULTS FOR ALL NIGHTTIME PARTICIPANTS.	50
TABLE 14. ROUTE SEGMENT FAMILIARITY FOR ALL NIGHTTIME PARTICIPANTS.	50
TABLE 15. NUMBER AND PERCENT OF COMMENTS FOR NIGHTTIME PARTICIPANTS IN RESPONSE TO THE QUESTION: “WHAT WAS MOST MEMORABLE ABOUT THE DRIVE? FOR EXAMPLE, WERE THERE ANY OBJECTS THAT STOOD OUT?”	52

ABSTRACT

The results of a naturalistic study showed that several driving performance measures in the presence of digital billboards are on a par with those associated with everyday driving, such as the on-premises signs located at businesses. These performance measures included eyeglance performance, speed maintenance, and lane keeping. The current study was conducted in Cleveland, OH following the model of a previous study conducted in Charlotte, NC (which showed no measurable effects of conventional billboards on eyeglance patterns, speed maintenance, or lane keeping). Thirty-six drivers drove an instrumented vehicle on a 50-mile loop route in the daytime along some of the interstates and surface streets in Cleveland. Participants were not informed about the true purpose of the experiment, and were told that the purpose was to help understand the way people drive in a natural environment. Along the route, participants encountered five digital billboards, 15 conventional billboards, 12 comparison sites (similar to items you might encounter in everyday driving), and 12 baseline sites (sites with no signs). Twelve participants returned for a nighttime session to explore the potential effects of the digital billboards at night.

The eight seconds leading up to the events of interest were then analyzed in terms of eyeglance patterns, speed maintenance behavior, and lane keeping behavior. In a post-drive questionnaire, 42% of drivers mentioned billboards as one of the top five items that caught their attention (out of 18 choices). Eyeglance results showed that there were no differences in the overall glance patterns (percent eyes-on-road and overall number of glances) between event types. Drivers also did not glance more frequently in the direction of digital billboards than in the direction of other event types, but drivers did take longer glances in the direction of digital billboards and comparison sites than in the direction of conventional billboards and baseline sites. However, the mean glance length towards the digital billboards was less than one second. Various researchers have proposed that glance lengths of 1.6 seconds, 2.0 seconds, and longer may pose a safety hazard. An examination of longer individual glances showed no differences in distribution of longer glances between the four event types. There were only minor differences in speed maintenance or lane keeping performance for the four event types.

The overall conclusion, supported by both the eyeglance results and the questionnaire results, is that the digital billboards seem to attract more attention than the conventional billboards and baseline sites. Because of the lack of crash causation data, no conclusions can be drawn regarding the ultimate safety of digital billboards. Although there are measurable changes in driver performance in the presence of digital billboards, in many cases these differences are on a par with those associated with everyday driving, such as the on-premises signs located at businesses.

EXECUTIVE SUMMARY

The most notable findings from this study are as follows:

- Eyeglance results showed that there were no differences in the overall glance patterns between digital billboards, conventional billboards, comparison events, and baseline events during the daytime.
- Drivers did not glance more frequently in the direction of digital billboards than in the direction of other event types during the daytime.
- Drivers took longer glances in the direction of digital billboards and comparison sites than in the direction of conventional billboards and baseline sites during the daytime.
- An analysis of glances lasting longer than 1.6 seconds indicated that these longer glances were distributed evenly across the digital billboards, conventional billboards, comparison events, and baseline events during the daytime.
- The nighttime results indicate that digital billboards and comparison events may be associated with more active glance patterns, as well as with more frequent and longer glances towards the digital billboards and comparison events.
- For the post-drive questionnaire, 42% of drivers mentioned billboards as one of the top five items that caught their attention; note that drivers did not know this was billboard study.
- In an open-ended question, three drivers mentioned billboards as the single most memorable item on the trip, and two referred specifically to the digital billboards as being memorable.

The motivation for the current study was to examine driver performance in the presence of digital billboards, as compared to other driving locations without them. There is a long history of studying billboards in the context of traffic safety but, although the research record covers many years (1951 until the present), it is lacking in volume and is primarily focused on conventional billboards. There were a few epidemiological studies performed in the early 1950's examining traffic accidents in the presence and absence of billboards; however, much of this early work was methodologically flawed. After a long gap in research, there were a few additional studies in the 1960's through the 1980's, none of which demonstrated that billboards are unsafe. More recent studies conducted in Canada have shown that there may be changes in driver behavior associated with video billboards (those with full motion), but those studies do not address the digital billboards of interest in the current study (with a static message that changes instantaneously without special effects).

Traffic accident analysis techniques have improved in recent years with the creation and maintenance of national crash databases. A careful examination of these databases shows that distraction caused by billboards fails to show up in any of the accident databases as an accident cause. Likewise, an examination of numerous driver distraction studies demonstrates that billboards fail to show up as a cause of driver distraction. The overall conclusion from all past research is that conventional billboards in general have not been shown to cause traffic accidents or change driver behavior. However, the question of whether digital billboards change driver behavior in some way cannot be answered by these previous studies; this is the motivation for the current study.

The current study was conducted in Cleveland, OH to assess the effects, if any, of digital billboards on driver behavior and performance. The study was conducted following the model of a previous study conducted in Charlotte, NC that showed no measurable effects of conventional billboards on eyeglance patterns, speed maintenance, or lane keeping. Thirty-six drivers were recruited with males and females equally represented; they were also equally divided by age (older: 50-75, younger: 18-35). Participants drove an instrumented vehicle on their own (without an experimenter in the vehicle) on a 50-mile loop route in the daytime along some of the interstates and surface streets in Cleveland. Participants were not informed about the true purpose of the experiment, and were told that the purpose was to help understand the way people drive in a natural environment. Along the route, participants encountered the following items:

- 5 digital billboards (all that were available on the route). The digital billboards were the standard bulletin size (14 ft x 48 ft) and the copy changed instantaneously every eight seconds (there were no special effects during the transition).
- 15 conventional billboards (similar to those studied in the Charlotte study).
- 12 comparison sites (similar to items you might encounter in everyday driving; comparable to digital billboards in terms of visual activity/attractiveness, including on-premises signs [some with digital elements], logo placards, landmark buildings, and murals).
- 12 baseline sites (sites with no signs).

After the drive, participants completed a questionnaire regarding which types of items and activities they had noticed along the route. Participants were paid a nominal amount for their participation. Twelve participants returned for a nighttime session to explore the potential effects of the digital billboards at night.

The eight seconds leading up to the events of interest were then analyzed in terms of eyeglance patterns, speed maintenance behavior, and lane keeping behavior. With 36 participants and 44 sites, there were 1,584 events available for analysis from approximately 63 hours of data collection. A small amount of data was lost due to cell phone use, sensor outages, sun angle, and vehicle stoppages, leaving 1,540 events for eyeglance analyses. Altogether, 124,740 video frames were analyzed and 10,073 individual glances were identified. The speed data were filtered to remove events as described above, and then further filtered to remove low speed events, leaving 1,494 events in this dataset, with 121,014 data points. The lane position dataset was further filtered to remove events indicating a possible lane change or lane position sensor failure (often due to poor lane markings). After filtering, there were 1,188 events remaining in the lane position dataset, with 96,228 data points.

In terms of demographics, the average age was 28 years for younger drivers and 59 years for older drivers. Most had completed high school, but few had attended college. All participants lived in the Cleveland area, and were familiar with at least some parts of the route. For the post-drive questionnaire, 42% of drivers mentioned billboards as one of the top five items that caught their attention (out of 18 choices). In a later open-ended question, three drivers mentioned billboards as the single most memorable item on the trip, and two referred specifically to the digital billboards as being memorable. By way of contrast, only 25% of drivers in the Charlotte study checked off billboards in their top five list (of 18 choices), and none mentioned billboards as being the most memorable aspect of the trip. Recall that drivers did not know that the purpose

of the study was to examine performance in the presence of billboards; in fact, they did not know that the study had anything to do with billboards.

Eyeglance results showed that there were no differences in the overall glance patterns (percent eyes-on-road and overall number of glances) between event types (digital billboard, conventional billboard, comparison events, and baseline events). Drivers also did not glance more frequently in the direction of digital billboards than in the direction of other event types. However, drivers did take longer glances in the direction of digital billboards and comparison sites than in the direction of conventional billboards and baseline sites. Given that three of the comparison sites had digital components, the similar eyeglance findings for these two event types are not surprising. An analysis of glances lasting longer than 1.6 seconds showed no obvious differences in the distribution of these longer glances across event types.

There were differences in speed maintenance, with conventional billboards showing greater variation in speed than digital billboards. However, this was thought to be the result of a road type interaction, given that all of the digital billboards were on interstates. When only interstate events were considered in the analysis, there were no significant differences in speed maintenance across event types. There was a trend towards poorer lane keeping performance for digital billboards and conventional billboards; however, this trend failed to reach significance.

A smaller exploratory study was also conducted at nighttime using a slightly shortened route. Given that the digital signs being studied were intrinsically illuminated, this was felt to be an important first step in determining whether there are driver performance differences in the presence of these signs under different levels of ambient illumination. Twelve drivers were used, again divided equally by age and gender. All of the nighttime drivers had previously driven the route during the daytime and were thus somewhat familiar with the route (so were unlikely to get lost or go off route). The nighttime study was exploratory in nature with fewer data points, so these data were examined descriptively rather than analyzed statistically (due to lack of statistical power).

Four eyeglance measures were examined for the nighttime data: eyes-on-road percent, overall glance frequency, mean glance duration in the direction of an event, and mean number of glances in the direction of an event. The eyes-on-road measure showed that digital billboards and comparison events tended to have less eyes-on-road time at nighttime than either baseline events or conventional billboards. The overall glance frequency was also higher in the presence of digital billboards and comparison events than in the presence of baseline events and conventional billboards. These two findings taken together show a more active glance pattern at nighttime in the presence of these two event types. The mean glance duration for glances in the direction of an event also showed higher values for digital billboards and comparison events. Finally, the mean number of glances in the direction of an event also showed digital billboards and comparison events as having higher values than either baseline events or conventional billboards. Taken together, these four findings indicate that digital billboards and comparison events *may* result in more active glance patterns overall, as well as more frequent and longer glances towards the digital billboards and comparison events at nighttime.

Two driving performance measures were examined for the nighttime data: standard deviation of speed and standard deviation of lane position. The standard deviation of speed appeared to be higher in the presence of both conventional and digital billboards than for baseline and comparison events. Lane keeping also showed a trend towards greater lane deviations in the presence of both digital billboards and conventional billboards.

The luminance values of many of the billboards, comparison events, and baseline events were also measured at nighttime. The digital billboards had noticeably higher luminance values than any of the other event types, even though their luminance was automatically reduced at night. This probably explains some of the driver performance findings in the presence of the digital billboards. The overall ranking of luminance by event (digital billboards were the highest, followed in order by comparison events, conventional billboards, and baseline events) closely mirrors the rankings of many of the performance measures for both daytime and nighttime, including eyeglance, speed maintenance, and lane keeping.

The overall conclusion, supported by both the eyeglance results and the questionnaire results, is that the digital billboards seem to attract more attention than the conventional billboards and baseline sites (as shown by a greater number of spontaneous comments regarding the digital billboards and by longer glances in the direction of the billboards). The comparison events, 25% of which included signs with digital components, showed very similar results to the digital billboards. Thus, there appears to be some aspect of the digital billboards and comparison events that holds the driver's attention, once the driver has glanced that way. This is most likely the result of the intrinsic lighting of these signs, which is noticeable even during the daytime. Drivers may also have maintained longer glances towards the digital billboards in the hopes of catching the next message (knowing that the message changes periodically). Although exploratory in nature, the nighttime results were very similar to the daytime results, with indications of degraded driving performance for digital billboards and comparison events.

These particular LED billboards were considered safety-neutral in their design and operation from a human factors perspective: they changed only once every eight seconds, they changed instantaneously with no special effects or video, they looked very much like conventional billboards, and their luminance was attenuated at night. It is thus quite likely that digital signs with video, movement, higher luminance, shorter on-message duration, longer transition times, and special effects would also be related to differences in driver behavior and performance. Because of the lack of crash causation data, no conclusions can be drawn regarding the ultimate safety of digital billboards. Although there are measurable changes in driver performance in the presence of digital billboards, in many cases these differences are on a par with those associated with everyday driving, such as the on-premises signs located at businesses. Conventional billboards were shown both in the current study and in the Charlotte study to be very similar to baseline and comparison events in terms of driver behavior and performance; thus, the design of digital billboards should be kept as similar as possible to conventional billboards.

INTRODUCTION

There is a long history of studying billboards in the context of traffic safety, but although the research record covers many years (1951 until the present), it is lacking in volume. There were a few epidemiological studies performed in the early 1950's examining traffic accidents in the presence and absence of billboards. As will be seen, much of this early work was methodologically flawed. After a long gap in research, there were a few additional studies in the 1960's through the 1980's, none of which demonstrated that billboards are unsafe. Traffic accident analysis techniques have improved in recent years with the creation and maintenance of national crash databases. A careful examination of these databases shows that distraction caused by billboards fails to show up in any of the accident databases as an accident cause. Likewise, an examination of numerous driver distraction studies demonstrates that billboards fail to show up as a cause of driver distraction. The lead author of this report recently participated on an expert panel charged with providing recommendations for a minimal data set to be included on police accident reports; billboards were never raised as a possible distraction or as an item that should be included on these accident reports.

As will be seen, there has been relatively little research on billboards and their effect on driver behavior, and little original research on digital billboards of the type discussed in this report. The current project was therefore undertaken to fill this research gap and to determine whether digital billboards do in fact cause a change in driver behavior as he/she passes a billboard location. Several measures of eyeglance location were used as primary measures of driver visual behavior. Additional measures of driver performance were included to provide further insight--these included speed variation and lane deviation. Drivers in this study used an instrumented vehicle, drove the route alone, and were uninformed as to the purpose of the study.

The report is organized as follows: a literature review, covering topics such as early accident analysis studies, sign conspicuity studies, and later safety and driver distraction studies; a methods section; a results section; conclusions; references; and supporting material contained in appendices.

REVIEW OF PREVIOUS RESEARCH

Early studies from the 1950's attempted to correlate the occurrence and frequency of accidents with the location of billboards or other roadway or roadside features. For example, a series of studies by the Minnesota Highway Department (Rykken, 1951) analyzed accident features in order to determine whether there was any direct relationship between accident frequency and type and several elements of roadway and roadside design, including advertising sign type and location. While a relationship between frequency of access points and accident occurrence was evident, no apparent relationship was found between accident occurrence and advertising sign type or location.

Rykken (1951) added that more accurate accident reports might reveal an unexpected relationship between signs and accidents: the absence of signs when no other roadside objects are present may increase the likelihood of accidents by decreasing the driver's sense of a need for caution. Immediately after 45 miles of highway with no billboards or advertising signs in viewable distance, a roadside interviewing station investigated driver response. Because drivers expressed a feeling of fatigue and unease after having driven the section, the author postulated that the combination of a small number of distracting features and the complete absence of billboards produced a feeling of security, which tends to result in higher average driving speed. Several severe accidents that occurred over that stretch were attributed to excessive speed.

McMonagle, a researcher with the Michigan State Highway Department, analyzed 2,675 accidents on a 70-mile strip of highway from 1947 to 1948 in order to measure the relationship between accidents and highway design and roadside features (McMonagle, 1951). The strip of road included a variety of roadside features and design characteristics, including the number of lanes and traffic volume. Findings showed that the highest incidence of crashes occurred near intersections, particularly when gas stations, restaurants and other establishments were clustered nearby. Only a slight association (correlation coefficient .11) existed between large advertising signs and accidents. While total advertising signs correlated with accident frequency to a greater degree (correlation coefficient .41), advertising signs still contributed less to accident frequency than did groupings of design features or roadside features such as gas stations.

In an attempt to correlate accident frequency with density of advertising and roadside business, Rusch (1951) analyzed crash reports originating in 1947 and 1948 that examined sections of highway distributed across Iowa. The accidents were assigned one of three causes: 1) roadside business, 2) inattention or misdirected attention, or 3) "other causes." Roadside business was listed as the cause of an accident only if the business was specifically named in the accident report, as in the case of a vehicle exiting a gas station and being struck by oncoming traffic. Results showed that twice as many collisions occurred on the portions of road in the high-density category than occurred on the other parts of the test stretches put together. More accidents were attributed to inattention than to any other cause in the high-density category. In the low-density category, more accidents were attributable to miscellaneous causes than to business and inattention combined. Sections of highway in the low-density category showed lower accident rates than those in the high-density category, even when traffic volume was held constant. In addition, accidents on low-density stretches occurred more sporadically with less of a tendency to recur in the same locations the following year. In reference to this study, Andreassen (1985)

later claimed that “the greatest number of inattention accidents occurred on the sections where business and advertising predominated as the roadside property usage, but this does not prove anything about the effect of advertising signs on accident occurrence.”

Overall, these early studies provided some initial insight into accident causation, but did not demonstrate that billboards or other advertising signs were a possible cause of accidents. Intersections and high-density roadways combined with inattention were most commonly associated with an increased number of accidents. Interestingly, later analysts using modern statistical techniques critiqued these early studies as being methodologically flawed (e.g., Wachtel and Netherton, 1980; Andreassen, 1985).

A critical research review sponsored by the Federal Highway Administration (FHWA; Wachtel and Netherton, 1980) summarized knowledge concerning commercial electronic variable-message signage (CEVMS) in an effort to recommend national standards for their regulation. Because there was little research available in the area of CEVMS, their literature review focused on standard (conventional) billboards. Wachtel and Netherton (1980) opined that roadside advertising research based on accident studies has had limited value owing to either insufficient information concerning location and traffic or problems with statistical analysis and sampling error. While some studies have found positive relationships between outdoor advertising and accident frequency, others have arrived at the opposite conclusion.

According to Wachtel and Netherton (1980), human factors laboratory research techniques are capable of gathering much more precise, reliable, and valid data in the attempt to measure and explain the effect of outdoor advertising on driver behavior. Literature from several related fields indicated that outdoor advertising probably does not hurt driving performance noticeably when driving conditions are favorable (in terms of weather, traffic, road, vehicle, etc.). This is because the driver has sufficient spare processing capacity to pay attention to the signs without compromising the primary task. When stimulation is extremely low, as when there is very little traffic and very little to look at or to decide, unusual environmental features such as road signs may increase the driver’s arousal and improve driving performance. When the driving task becomes highly demanding, the outdoor advertising must compete with more vital information sources such as traffic, weather, and official signage.

In a review of published literature relating accidents to advertising signs, Andreassen (1985) brought attention to weaknesses in the small amount of research that has been conducted in this area. Almost all studies have relied on correlations and/or subjectively assigned “inattention” factors, which can only produce very tenuous evidence for a causal link between advertising and accident frequency.

Garvey, Thompson-Kuhn, and Pietrucha (1995) reviewed the studies that attempted to evaluate directly the relationship between traffic accidents and advertising signs. The common problem with these studies is attributing accident causation; high-advertising and low-advertising sites may have different accident frequencies because of differing traffic densities, pedestrian activity, and roadway geometry. Although most evidence argues against a strong causative link, it is still not possible to ascertain the existence or nature of the relationship between advertising and accidents.

Recently, much attention has been focused on the causes and effects of distraction on driving, especially in the area of cellular phones and other in-vehicle technology. A review of the recent driver distraction literature failed to reveal any studies in which outdoor advertising was mentioned as a cause for driver distraction. As a matter of fact, this report's lead author recently served on the advisory panel for the revised Model Minimum Uniform Crash Criteria in which transportation safety experts recommended revisions to the minimum set of data to be collected as part of every crash report. There were lengthy discussions over which distraction variables should be recommended, and the words "billboard" or "advertising" were never mentioned.

The national crash databases do not mention billboards in their list of driver distractions. The two most prominent databases are the General Estimates System (GES), which estimates the number of all crashes based on a representative sample, and the Fatal Accident Reporting System (FARS), which is a true census of every fatal crash. The only mention of billboards in the 216 page user's manual for the GES database is in the Driver's Vision Obscured By variable, which has a category of Building, Billboard, or Other Design Features (GES, 2002). In other words, if an accident was caused by a driver's vision being obscured, billboards would be lumped together with buildings and other design features, both of which are much more common than billboards. The same holds true for the FARS user's manual of 458 pages – billboards are only mentioned in the Driver's Vision Obscured By variable, and are lumped together with buildings (Tessmer, 2002).

One recent study of driver distraction (Glaze and Ellis, 2003) reported one mention of the word "billboard" in the context of an accident caused by driver distraction. Glaze and Ellis performed a study to determine the nature of distraction/inattention crashes in the state of Virginia. A complex system of accident report sampling was administered via surveys sent to all seven Virginia state police divisions, four selected counties, and 14 independent cities. Roughly 2,800 crash scenes were reported, involving a total of almost 4,500 drivers. At least one distracted driver was involved in 98% of those crashes. Every accident report had a space to write an open-ended description of the main distracting factor in the accident, and over 1,400 responses were recorded. One response (out of 2,800 crashes) included a billboard being repaired as a causal factor for driver distraction leading to a crash. No mention of outdoor advertising was made in any other place in the study, despite the fact that 35% of distracters were outside of the vehicle in question (62% were in-vehicle and 3% were unknown). Typical in-vehicle distracters included passenger/children distraction (8.7%), adjusting radio/changing CD or tape (6.5%), eating or drinking (4.2%), and cell phone (3.9%). Typical out of vehicle distracters included looking at crash, other roadside incident, or traffic (13.1%), looking at scenery or landmarks (9.8%), and weather conditions (1.9%). There were also 25 cases of drivers being distracted by traffic signs or signals (<1%).

Tantala and Tantala (2005) have been the most recent researchers to attempt a rigorous examination of the relationship between advertising signs and traffic accidents. They used methods intended to control for the analytical issues noted with early studies of this type. They conducted two analyses for this research. In the first situation, a highway (New Jersey Turnpike) with advertising signs was selected and studied, including analysis of sign location, road conditions, and traffic-accident locations, to determine whether traffic accidents were more

prevalent at or near existing signs. More than four years of data and 23,000 accidents were used in this analysis. Statistical correlation coefficients showed that the correlation was statistically low for all analyses conducted, including accident density and sign density (with and without interchanges included), accident distance and viewer reaction distance (again with and without interchanges included), and accident density and proximity to the sign. They also found that these correlation values were consistent from year to year. This section of the analysis led them to conclude that there are no statistical or causal relationships between advertising signs and accidents.

In the second analysis by Tantala and Tantala (2005), the location of a recently installed sign was identified, and the incidence of traffic accidents near the sign was examined. Accidents before and after sign installation were examined to determine whether traffic accidents occurred more frequently in the presence of the sign. The sign was installed at a busy intersection near a mall in Pennsylvania. The intersection was controlled by a traffic signal. One year of pre-installation and one year of post-installation data were compared. There were no other changes to the intersection during the two year study period. After installation of the sign, the traffic volume increased, the accident rate decreased, the maximum number of accidents in any given day or week decreased, and the number of days without accidents increased. There were no statistically significant changes in accident occurrences after the installation of the advertising sign.

Researchers are beginning to conduct more studies of driver performance in the presence of various types of advertising signs. For example, Beijer, Smiley, and Eizenman (2004) studied video advertising signs (those with full motion displays) in Toronto using eyegance analysis similar to that used in the Charlotte study. They compared the video signs to two other types of active signs (scrolling text and roller bar) and to conventional billboards. Significantly more glances, and even more importantly, significantly more glances that lasted ≥ 0.75 s were made to video signs than to scrolling text, roller bar, or conventional billboard signs. Taking all active signs together, these received significantly more glances and significantly more long glances per sign than the conventional billboards. However, there were no digital billboards of the type studied in the current research effort.

The most recent research paper in this area was conducted by Crundall, Van Loon, and Underwood (2006). They conducted a laboratory study to examine the differences between street level advertising (such as advertising on bus shelters) and raised level advertising (the same sorts of signs, but raised 10 ft above the ground). They concluded that street level advertisements attract and hold attention at inappropriate times as compared to raised level advertising. Since the billboards studied in the current report were never at ground level, this paper provided no new useful information.

It should be noted that the Virginia Tech Transportation Institute (VTTI) undertook another project for the Foundation for Outdoor Advertising Research and Education (FOARE) (Lee, Olsen, and DeHart, 2004). This project was undertaken in Charlotte, NC using methods similar to those used in the current study to determine whether there is any change in driving behavior in the presence or absence of conventional billboards. Several measures of eyegance location were used as primary measures of driver visual performance. Additional measures were included to provide further insight into driving performance; these included speed variation and lane

deviation. The overall conclusion from this study was that there is no measurable evidence that billboards cause changes in driver behavior in terms of visual behavior, speed maintenance, and lane keeping. A rigorous examination of individual billboards that could be considered to be the most visually attention-getting demonstrated no measurable relationship between glance location and billboard location. Driving performance measures in the presence of these specific billboards generally showed less speed variation and lane deviation.

Participants in this study drove a vehicle equipped with cameras in order to capture the forward view and two views of the driver's face and eyes. The vehicle was also equipped with a data collection system that would capture vehicle information such as speed, lane deviation, Global Positioning System (GPS) location, and other measures of driving performance. Thirty-six drivers participated in the study, driving a 35-mile loop route in Charlotte, NC. A total of 30 billboard sites along the route were selected, along with six comparison sites and six baseline sites. Several measures were used to examine driving performance during the seven seconds preceding the billboard or other type of site. These included measures of driver visual performance (forward, left, and right glances) and measures of driving performance (lane deviation and speed variation).

With 36 participants and 42 sites, there were 1,512 events available for analysis. A small amount of data was lost due to sensor outages, sun angle, and lane changes, leaving 1,481 events for eyeglance analysis and 1,394 events for speed and lane position analysis. Altogether, 103,670 video frames were analyzed and 10,895 glances were identified. There were 97,580 data points in the speed and lane position data set.

The visual performance results indicate that billboards do not differ measurably from comparison sites such as logo boards, on-premises advertisements, and other roadside items. No measurable differences were found for visual behavior in terms of side of road, age, or familiarity, while there was one difference for gender. Not surprisingly, there were significant differences for road type, with surface streets showing a more active glance pattern than interstates. There were also no measurable differences in speed variability or lane deviation in the presence of billboards as compared to baseline or comparison sites. An analysis of specific, high attention-getting billboards showed that some sites show a more active glance pattern than other sites, but the glance locations did not necessarily correspond to the side of the road where the billboards were situated. Taken as a whole, the results of the previous research conducted for FOARE support the overall conclusion that driving performance does not change measurably in the presence or absence of billboards.

The only currently available research report related to electronic billboards is a literature review sponsored by the FHWA (Farbry, Wochinger, Shafer, Owens, and Nedzesky, 2001). The motivation for this report was to fill the knowledge gap in this area since the last attempt by Wachtel and Netherton in 1980. However, the material does not appear to address the instantaneously changing digital billboards of the type discussed in the current report. Examples shown pictorially in Farbry et al. (2001) are signs with changeable elements (such as time and temperature signs), tri-vision signs, and video digital billboards of the type studied by Beijer et al. (2004). Farbry et al. (2001) raised questions about safety implications with regard to driver distraction, summarized current knowledge in this research field, assessed areas needing

exploration, and developed a research plan to address them. While some electronic billboards (EBBs) display motion and color with fine detail, others just show a short sequence of words in which each letter is composed of a matrix of LEDs (Farbry et al., 2001). This type of display is also used by governmental agencies to present information to drivers and is known by several different acronyms: variable message sign (VMS); dynamic message sign (DMS); and changeable message sign (CMS). A tri-panel sign, also known as a tri-vision sign, is composed of triangular cylinders that rotate periodically, showing a different composite image in between each rotation. The only movement is that of the images in transition.

Studies attempting to draw causality from correlation between dynamic billboards and accident frequency run into the same difficulties found by studies investigating conventional billboards and accidents (Farbry et al., 2001). Common obstacles include consistently confounding traffic conditions in areas with heavy advertising, incomplete or inaccurate accident reports, and driver motivation to omit distraction when reporting crash causality. Even given these stumbling blocks, the correlation is still statistically clear: after a *dynamic*, illuminated billboard is installed, crash rates go up. A common trend was exemplified when a 35% increase in sideswipe and rear-end accidents on an interstate occurred after a variable message advertising sign was put up on the side of a sports stadium. The correlation, while rarely this dramatic, is a consistent one. However, even a correlation this strong is not sufficient evidence to assume causality. Enough other variables were held to be confounding the situation that the sports stadium sign was not deemed a traffic hazard in and of itself, and it remained in place for 16 years.

Farbry et al. (2001) caution that correlations alone provide little fodder for the development of countermeasures. Researchers hypothesize that a safety hazard is posed by dynamic advertising because it may cause greater distraction, which can be measured in several formal ways. One common method is to ask the driver to perform another task while driving, then to measure the degree to which the safe operation or control of the vehicle is affected. Lack of control is typically quantified by one of three measures: lateral deviation, maintenance of appropriate speed, and/or braking for emergencies. Lateral deviation is defined as either the degree to which the vehicle swerves away from the center of the appropriate lane or a measure of the variability in steering wheel position. Maintenance of appropriate speed refers to the headway between the vehicle and the vehicle ahead; if the lead vehicle slows down, the participant vehicle should also slow down and maintain an appropriate speed to keep the headway constant. Some experiments present an emergency and measure distraction by the amount of time it takes the participant to respond appropriately.

The literature review by Farbry et al. (2001) also revealed that the two demographic groups most susceptible to the dangers of distraction while driving are drivers over the age of 65 or under the age of 24. Older drivers' visual processing speed and attention degrade with age, resulting in little to no spare resources with which to encode and process anything but the most important information in the driving environment. Younger drivers usually have faster processing speeds, but they are less experienced and less efficient at resource allocation. Among other weaknesses, younger drivers take more risks, may not recognize hazards, and have poor focus on the driving task itself. Because of this, they may be more vulnerable to having their attention drawn by irrelevant but attention-getting stimuli.

Other than age, a variable that may influence the degree to which a sign distracts a driver is route familiarity (Farbry et al., 2001). A driver who is new to a road may be looking for navigational or service cues, and this task may take longer in a more complex visual environment containing numerous advertising signs. On the same road, a familiar driver may not look around much since he already has all of the information that he needs. Familiar signs may be less likely to attract the attention of a driver who knows the roadway well and whose primary navigational interests may be traffic conditions and incidents. According to this theory, a visitor would be more likely to be distracted by an advertising sign than would a commuter.

Research regarding distraction, conspicuity, and legibility revealed that an increase in distraction, a decrease in conspicuity, or a decrease in the legibility of a sign may cause an increase in the crash rate (Farbry et al., 2001). The review shows that, at this point, there is no effective technique for evaluating safety effects of EBBs on driver attention or distraction. Crash studies may show a positive correlation between dynamic signs and crash rates, but driver age and route familiarity are examples of confounding variables whose interference may hide the fact that very little causality can be proven.

The final recommendation of the Farbry et al. (2001) report is for further research in this area. They recommend research using several methods, including crash analysis of the sort conducted by Tantala and Tantala (2005), simulator research, test track research, and field studies. Simulator and test track research both have limitations with regard to sign research, especially in regard to digital billboards. For example, it can be difficult to achieve the visual effect of an internally illuminated sign in a simulator. For test tracks, only a limited amount of driving performance data could be obtained, which would likely not be worth the expense of installing a digital billboard on the test track. However, both test track and simulator research are more appropriate for highly controlled experiments in which the goal is to obtain information about the design and content of the billboard copy, the timing of the change, and other design elements. If the goal is to evaluate driver performance and behavior in the presence of digital billboards that occur in the natural course of driving, then a field study is the appropriate technique, and this was the technique selected for the current study.

The overall conclusion from all past research is that conventional billboards in general have not been shown to cause traffic accidents or change driver behavior. However, the question of whether digital billboards change driver behavior in some way cannot be answered by these previous studies; this is the motivation for the current study.

METHOD

Selection of City

Both Pittsburgh, PA and Cleveland, OH were scouted as possible locations for conducting this study. The Pittsburgh streets where the digital billboards were located were generally very curvy and hilly, often with nearby intersections. The digital billboards were often situated at the bottom of a hill, at a curve, or just beyond an intersection. It would have thus been difficult to conduct meaningful eyeglance and speed analyses under these conditions (i.e., the signs were situated in most cases such that the driver had to look straight forward to see the signs). The Cleveland digital billboards, on the other hand, were located off to the side of the roadway in straight-away sections of interstate with no interference from hills, curves, or intersections. It was thus apparent that choice of Cleveland would allow for a more robust analysis with fewer dropped data points.

Digital Billboards

The item of interest in this study was digital Billboards. These billboards are illuminated from within via a matrix of LEDs. These devices are capable of displaying several messages in a rotation. The digital billboards are also capable of video and special transition effects (such as fades or wipes from one message to the next). However, the digital billboards used in this study simply transitioned from one message to the next in less than one second, using no transition special effects or video; in other words, there was no motion or apparent motion used in displaying the messages or transitioning between them. Messages changed once every eight seconds. The billboards appeared very similar to conventional billboards, except that the copy was crisper and easier to read from a distance even during the daytime, likely due to the intrinsic lighting. The lighting level was automatically dimmed at night to adjust to the ambient lighting level. Light measurements taken at night are presented in a different section of the report.

Experimental Design

This study was conducted as a mixed-factors research design (a 2 x 2 x 2 x 2 x 4 design, with four between-subjects cells). There were five independent variables: gender, age, route familiarity (determined post-hoc, so not balanced across subjects), event type, and road type. The between-subjects independent variables were gender (male or female) and age (younger or older). For the within-subjects variables, the levels were as follows: route familiarity (familiar or unfamiliar, defined later), event type (digital billboard, conventional billboard, baseline, and comparison, also defined later), and road type (interstate or surface roads). All of the participants drove each of the segments and were exposed to all of the billboards and comparison sites. A representation of the experimental design is included in Figure 1.

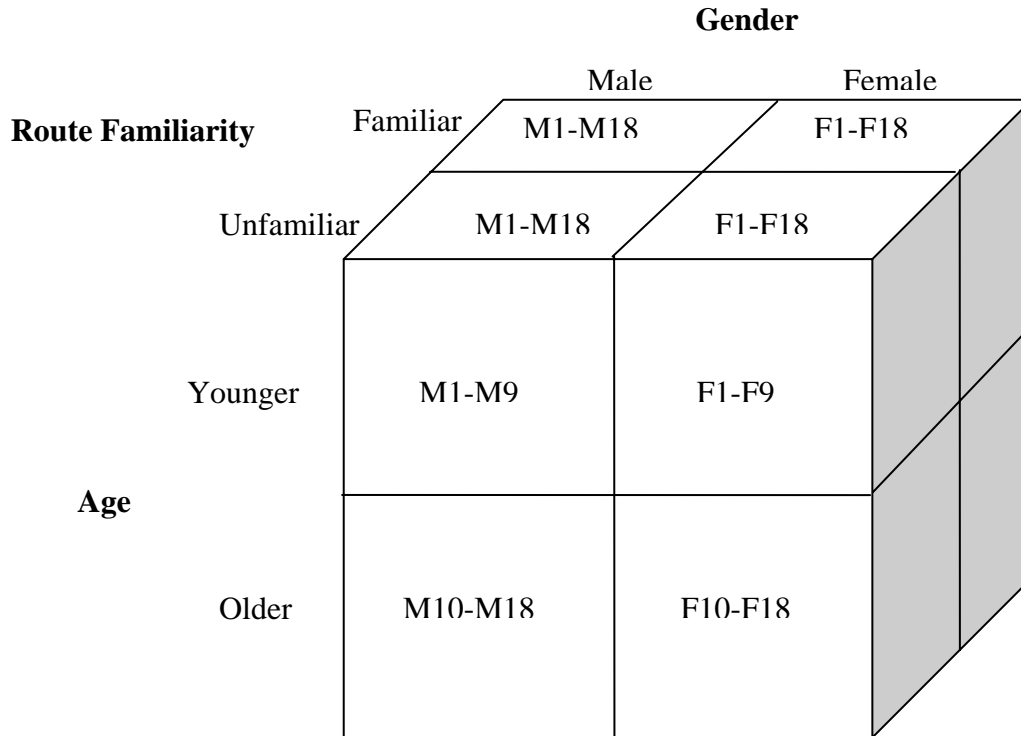

Figure 1. Assignment of Participants to Experimental Conditions.

Independent Variables

The five independent variables are listed in Table 1.

Table 1. Independent Variables.

Independent Variable	Levels
Age	Younger (18-35) or Older (50-75)
Gender	Male or Female
Route Familiarity	Unfamiliar or Familiar (familiarity with at least 4 segments determined for each subject)
Event Type	Digital Billboard, Conventional Billboard, Baseline (no billboards or other large signs) or Comparison (other signs or landmarks)
Road Type	Interstate or Surface Street

Age and Gender. Of the 36 participants, eighteen were younger drivers (18 to 35 years old) and eighteen were older drivers (50 to 75 years old). Eighteen of the participants were male and eighteen were female. Age was equally balanced across gender, as is illustrated by Figure 1 (e.g., of the 18 younger participants, 9 were male and 9 were female).

Route Familiarity. Route familiarity referred to how often a section was normally driven by the participant per week (unfamiliar = drove section less than once per week; familiar = drove

section at least once per week). Route familiarity was ascertained after the drive by asking participants how familiar they were with the various segments they had just driven. Thus, this variable was not balanced across the participant population.

Road Type. The two road types were interstates and surface roads. All of the participants were exposed to both road types. Approximately 85% of the route consisted of interstate segments, with the remainder being classified as surface streets.

Event Type. The four event types included digital Billboard, Conventional Billboard, Comparison, and Baseline. All of the participants were exposed to all four event types. Events were 8 seconds long (chosen because the digital billboards were programmed to change messages instantaneously once every 8 seconds; an event length of 8 seconds thus made it highly likely that a message change would be captured during the event). The end of an event was the point at which the experimental vehicle passed the object, and the start of the event was then defined as 8 seconds before the end point. All events on the route are listed and described in Table 2.

Digital Billboards. Five digital billboards were included along the driving route. Displays on the billboards changed instantaneously (i.e., no special effects such as fades, wipes, or shuttering occurred when the message changed) every 8 seconds; the signs followed standards for color, brightness, and placement. These five locations are shown in Figure 2 with the black dots (●).

Conventional Billboards. Conventional billboard events were defined as areas in which designated billboards were visible. These were identified by GPS coordinates (latitude and longitude) associated with their exact location near the roadway. Most of the billboards were the bulletin size, 14 ft (h) by 48 ft (w). Of the total set of billboards available on the route, a sample of 15 billboards was selected for efficiency of data reduction and to ensure a balanced sample. The sample was selected so that it was balanced in terms of side of the road, media type, road type, and (where possible) varying degrees of “visual clutter.” None of the selected boards were located directly prior to or after a road exit or entry (preliminary review of the video indicated that drivers were likely to be changing lanes or monitoring items such as road signs during these times, which could confound the results of the analysis). Each side of the road was equally represented to the degree possible, and most of the digital and conventional billboards were 14 ft x 48 ft bulletins. The remaining few were smaller boards, including standard poster, junior print, and 10’6” x 36’ bulletins. Table 3 lists the selected billboards, while the locations of the selected billboards are indicated by red dots (●) in Figure 2.

Comparison Sites. Comparison events were areas with visual elements other than billboards. Examples include on-premise signs, logo placards, interesting landmark buildings, large wall murals, and variable message signs. Several events had digital components. The events were chosen before data collection began and were selected based on the experimenters’ perception that these vents were comparable to the digital billboards in the visual attractiveness. These 12 sites are shown as aqua blue dots (●) in Figure 2.

Baseline events. The baseline event type referred to areas with no billboards or other large signs visible (except for perhaps speed limit and other small traffic control signs). These 12 areas

served as locations with which to compare velocity, lane position, and glance patterns and are indicated by blue dots (●) in Figure 2.

Table 2. Event Types Indicating Description, Side of the Road, Latitude, Longitude, and Specific Site Location Information.

	Event Type	Description	Side	Latitude	Longitude	Site	Road Type
1	4	Baseline	Both	41.41208267	-81.6701355	480 W, W/O Lancaster Dr.	I
2	2	Static Billboard	Left	41.42123795	-81.69820404	480 W, W/O Broadview Rd.	I
3	3	On Prem/Logo	Right	41.42151642	-81.70906067	480 W, E/O State Rd.	I
4	2	Static Billboard	Left	41.42173767	-81.71897125	480 W, E/O Pearl Rd.	I
5	4	Baseline	Both	41.42321014	-81.74341583	480 W, W/O Ridge Rd.	I
6	2	Static Billboard	Left	41.42559433	-81.76654053	480 W, W/O Tiedeman Rd.	I
7	2	Static Billboard	Right	41.42352295	-81.77274323	480 W, E/O W. 130th St.	I
8	1	LED Billboard	Left	41.42056274	-81.78245544	480 W, W/O W. 130th St.	I
9	3	On Prem/Logo	Left	41.42053986	-81.7904892	480 W, @ W. 139th St.	I
10	2	Static Billboard	Left	41.42324829	-81.80148315	4866 West 150th	S
11	4	Baseline	Both	41.4307785	-81.80125427	4545 West 150th	S
12	2	Static Billboard	Left	41.43348694	-81.79000854	13986 Puritas Ave	S
13	4	Baseline	Both	41.43657303	-81.78400421	13456 Bellaire Rd	S
14	3	On Prem/Logo	Left	41.43969727	-81.77674103	12686 Bellaire Rd	S
15	3	Tri-Vision Billboard	Right	41.44282913	-81.77227783	12071 Bellaire Rd	S
16	4	Baseline	Both	41.45092773	-81.76893616	3757 West 117th	S
17	2	Static Billboard	Left	41.46089554	-81.76893616	3370 West 117th	S
18	4	Baseline	Both	41.46966553	-81.75019836	90 E, @ W. 97th St.	I
19	1	LED Billboard	Right	41.47394943	-81.72478485	90 E, @ W. 55th St.	I
20	2	Static Billboard	Left	41.47385406	-81.70856476	90 E, W/O Fulton Rd.	I
21	3	On Prem/Logo	Left	41.48424911	-81.69098663	90 E, S/O Abbey Ave.	I
22	1	LED Billboard	Right	41.4903717	-81.68776703	90 E, @ W. 3rd St.	I
23	3	On Prem LED Billboard	Left	41.49866867	-81.67558289	2071 Carnegie Ave.	S
24	3	On Prem/Logo	Left	41.49928284	-81.67251587	2351 Carnegie Ave.	S
25	3	On Prem LED Billboard	Left	41.52510452	-81.66101074	90 E, E/O E. 49th St.	I
26	3	Building	Right	41.53549194	-81.64455414	90 E, W/O E. 72nd St.	I
27	2	Static Billboard	Right	41.54089737	-81.62488556	90 E, W/O E. 99th St.	I
28	2	Static Billboard	Right	41.54464722	-81.61724854	90 E, W/O E. 105th St.	I
29	4	Baseline	Both	41.5479126	-81.60997009	90 E, @ E. 109th St.	I
30	3	On Prem/Logo	Right	41.55478668	-81.59642029	90 E, @ Coit Rd.	I
31	4	Baseline	Both	41.56173325	-81.59170532	90 E, W/O E. 140th St.	I
32	4	Baseline	Both	41.56638718	-81.57984161	90 E, W/O E. 152nd St.	I
33	2	Static Billboard	Right	41.57143021	-81.56455994	90 E, @ E. 167th St.	I
34	3	On Prem/Logo	Right	41.57068634	-81.56790924	90 W, @ E. 161st St.	I
35	4	Baseline	Both	41.56744385	-81.57712555	90 W, W/O E. 152nd St.	I
36	4	Baseline	Both	41.55927277	-81.59375763	90 W, W/O E. 140th St.	I
37	1	LED Billboard	Left	41.54701233	-81.61243439	90 W, W/O E. 105th St.	I
38	2	Static Billboard	Left	41.54128647	-81.62450409	90 W, W/O E. 99th St.	I
39	3	On Prem LED Billboard	Right	41.52567673	-81.66069031	90 W, W/O E. 55th St.	I
40	2	Static Billboard	Left	41.49006653	-81.66697693	77S, S/O Woodland Ave.	I
41	2	Static Billboard	Right	41.48295593	-81.66287231	77 S, @ I-490 Exit	I
42	1	LED Billboard	Right	41.46414566	-81.65770721	77 S, S/O Pershing Ave.	I
43	4	Baseline	Both	41.45179367	-81.65712738	77 S, N/O Harvard Ave. Exit	I
44	2	Static Billboard	Left	41.4439621	-81.65229797	77 S, N/O Grant Ave. Exit	I

Event Type: 1=LED Billboard, 2=Static Billboard, 3=Comparison, 4=Baseline

Road Type: I=Interstate, S=Surface Street

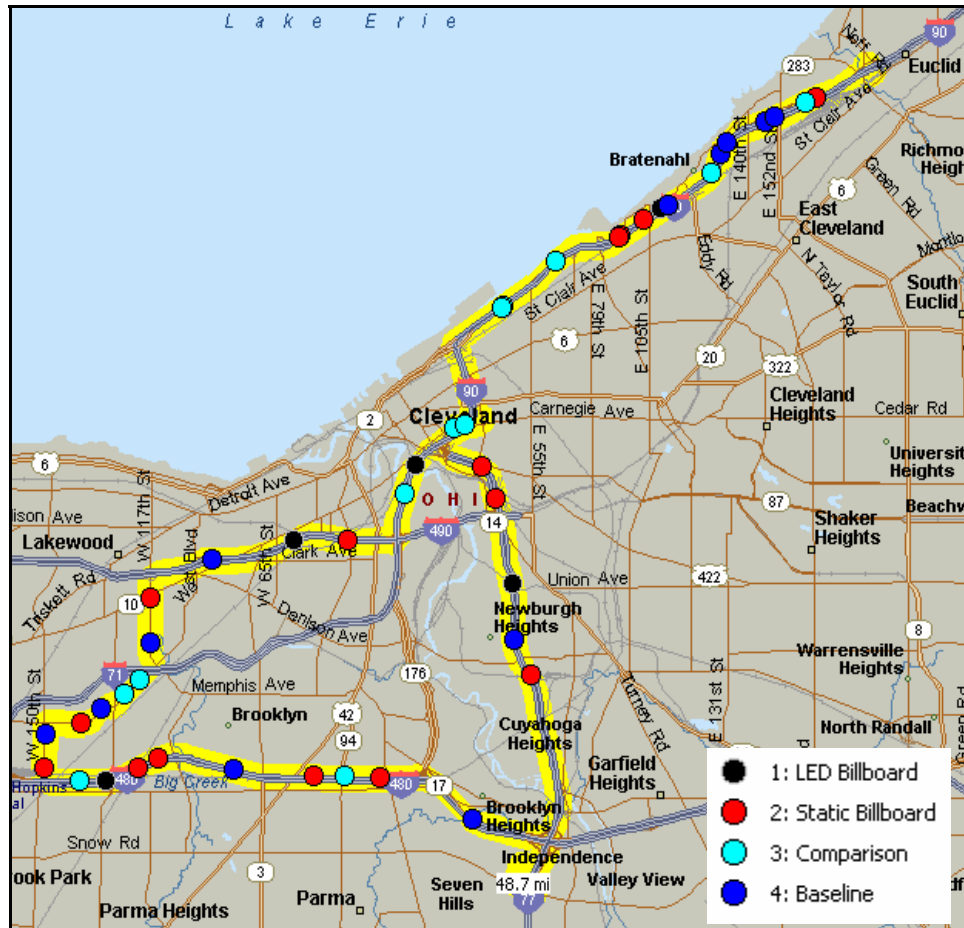

Figure 2. Map Illustrating Digital Billboards (black), Conventional Billboards (red), Comparison Sites (aqua blue), and Baseline Sites (blue).

Dependent Variables

The dependent variables are discussed in more detail in the results section, but they are reviewed briefly here. The purpose of the study was to determine if there are changes in driver behavior in the presence of billboards. Eleven dependent measures were used as indicators of driver behavior: nine eyegance measures and two driving performance measures. The nine eyegance measures included: total number of glances for center forward, left forward, and right forward; total glance duration for center forward, left forward, and right forward; and average glance duration for center forward, left forward, and right forward. Keep in mind that all glance locations reported here were out of the front windshield, but varied in location within the forward view. The two driving performance measures were speed deviation (standard deviation of speed over the 8 seconds of the event) and lane deviation (standard deviation of lane position over the 8 seconds of the event). Additional analyses examined driver glance behavior to certain other locations, including interior locations and exterior locations other than forward. The next section is a supplement to the literature review presented earlier, and lays the groundwork for the selection of these dependent variables, which are similar to those typically used in transportation safety research.

Selection of Dependent Variables Based on Previous Driving Studies

Measures of Visual Demand

According to Farber, Blanco, Foley, Curry, Greenburg, and Serafin (2000), typical measures of visual demand include: 1) glance frequency, 2) glance duration, 3) average duration per glance, and 4) total eyes-off-road time. Such measures are time-consuming to record and analyze but are typically used to measure visual attention. For example, previous research has reported on driver performance of in-car tasks such as adjusting the radio, viewing in-car displays (e.g., speedometer) or interacting with a navigation system (Wierwille, Antin, Dingus, & Hulse, 1988; Gellatly & Kleiss, 2000; Kurokawa & Wierwille, 1990; Tijerina, Palmer, & Goodman, 1999). Visual glance duration and the number of glances per task were investigated while performing conventional in-vehicle tasks and navigation tasks (Wierwille, Antin, Dingus, & Hulse, 1988). Findings indicated that glance frequency varied depending upon the task, and that glance duration for a single glance ranged from 0.62 s to 1.63 s. The mean number of glances across all tasks was between 1.26 and 6.52 glances. Zwahlen, Adams, and DeBald (1988) reported that “out of view” glance times (rear view mirror, speedometer, etc.) ranged from 0.5 s to 2.0 s during straight driving. Another example of such research is an experiment by Parkes, Ward, and Vaughan (2001) who measured glance frequency, glance duration, and average duration per glance to evaluate two in-vehicle audio systems, in terms of total “eyes off road” time.

Search and Scan Patterns

Early research included the investigation of visual search and scan patterns while driving (Mourant, Rockwell, & Rackoff, 1969; Mourant & Rockwell, 1970; 1972). It was found that as drivers became familiar with a route, they spent more time looking ahead, they confined their sampling to a smaller area ahead, and they were better able to detect potential traffic threats (e.g., movement in the periphery). Mourant and Rockwell (1970) found that peripheral vision was used to monitor other vehicles and lane line markers, that novice and experienced drivers differed in their visual acquisition process, and that novice drivers may be considered to drive less safely.

A recent field study investigated the influence of fatigue on critical incidents involving local short haul truck drivers (Hanowski et al., 2003). Fatigued drivers involved in critical incidents when making lane changes spent more time looking in irrelevant locations (i.e., locations other than out-the-windshield, out-the-windows, at the mirrors, or at the instrument panel). The mean proportion of time spent looking at irrelevant locations was 8%. However, during normal lane changes (not a critical event), the mean proportion of time that drivers spent looking at irrelevant locations was 3%, a significant difference. In terms of eye behavior, it appears that fatigued drivers involved in critical incidents pay less attention to relevant locations such as the road ahead and appropriate mirrors.

Mirror Glance Duration

Based on available literature discussed in this section, mirror glance times range from 0.8 s to 1.6 s ($M = 1.1$ s). Searches to the rear (blind spot) appeared to require a minimum value of 0.8 s. Nagata and Kuriyama (1985) investigated the influence of driver glance behavior in obtaining information through door and fender mirror systems. For door mirror systems, they reported that the average glance duration to the near-side (i.e., right side in this case) mirror was 0.69 s. Rockwell (1988) reported that the average glance duration to the left mirror was 1.10 s ($SD = 0.33$ s). This finding was consistent across different participants in three different experiments over a six-year period using the same data gathering and reduction technique. Taoka (1990) modeled the eyeglance distributions of Rockwell and found they could be well represented by means of a lognormal distribution. Taoka reported that the average time for viewing the left-side mirror was also 1.10s ($SD = 0.3$ s). The 5th percentile value was 0.68 s and the 95th percentile was 1.65 s. For right side mirror glances, Nagata and Kuriyama (1985) reported that average glance duration was 1.38 s (angle difference from the vertical axis of 70 degrees), while Rockwell reported an average glance duration of 1.21 s (10% larger than left glances), with an approximate standard deviation of 0.36 s. For the rear view mirror, Taoka (1990) reported that the average glance time was 0.75 s ($SD = 0.36$ s). The 5th percentile value was 0.32 s and the 95th percentile was 1.43 s.

Velocity

Velocity (traveling speed) has been used as a measure of driving performance for several decades. For example, Brown, Tickner, and Simmonds (1969) found that driving while telephoning had a 6.6% reduction in speed as compared to driving alone, in an early closed-circuit driving experiment. They also concluded that telephoning while driving may impair perception and decision-making skills. More recently, Alm and Nilsson (1994) concluded that a mobile telephone task while driving led to a reduction in speed level. In another effort, Tijerina, Kiger, Rockwell, and Tornow (1995) assessed driver workload for commercial vehicle operators in conjunction with using an in-vehicle device. Various measures were monitored including speed variance, which was highest for activities involving radio tuning and 10-digit cell-phone dialing tasks. Another study monitored speed for a driving study involving talking on a cell phone or talking to a passenger (Waugh, Glumm, Kilduff, Tauson, Smyth, & Pillalamarri, 2000). Results indicated that driving speeds were lower when talking on the phone as compared to talking to the passenger. It is generally recognized that tasks with high visual or cognitive demand can result in large deviations in speed.

Lateral Position

Lateral lane position or deviation is one of the most common measures of driver performance and distraction (Salvucci, 2002). Lane position can be measured in terms of lane exceedances (i.e., drift across the line between the current lane and the next lane) or, in the absence of actual lane crossings, lateral position in terms of distance from the center of the lane or the side lane line markings. Various researchers have used lateral position. For example, Serafin, Wen, Paelke, and Green (1993) conducted an experiment involving a driving simulator and car phone

tasks. Greater lane deviation was observed for dialing while driving as compared to tasks involving listening, talking, or mental processing. In another study, Alm and Nilsson (1994) reported that for difficult driving tasks, a mobile telephone task had an effect on the drivers' lateral position during various 500 m driving segments. Results indicated that the mobile-telephone task made drivers drive closer to the right lane line, especially for complex tracking tasks. In another study, Tijerina, Kiger, Rockwell, and Tornow (1995) evaluated various measures including lane position variance and lane exceedances. They concluded that lane keeping was degraded when performing message reading tasks. Again, multiple research findings indicate that high levels of visual and cognitive demand can result in a greater level of lane deviation.

Participants

Thirty-six participants who were familiar with the Cleveland, OH freeway system and downtown area were recruited. Participants were recruited via newspaper advertisement (Figure 3), flyers, and word of mouth. Participant selection was determined after a telephone screening and selection process. All participants were between the ages of 18 and 71, with equal gender representation (18 female, 18 male). The experimental protocol was approved by the Virginia Tech Institutional Review Board (IRB) prior to any contact with participants. Figure 4 illustrates an example of an experimenter seated in the experimental vehicle.

Driving Study
In Cleveland area, \$20/hr for 2 hrs.
Must be 18-35 or 50-75 yrs old w/
driver's lic. Virginia Tech
Transportation Institute.
Call 866-454-4568 or email
drivers @vtti.vt.edu

Figure 3: Newspaper Advertisement that appeared in the Cleveland Plain Dealer.



Figure 4. Experimenter Seated in Experimental Vehicle.

Route and Equipment

Route

The pre-planned loop route was approximately 50 miles long and consisted of sections on Interstates 480, 90, and 77, as well as surface streets in downtown Cleveland, OH. Prior to collecting any data, experimenters from VTTI visited the area several times in order to determine the final route by verifying the presence of suitable billboards. A potential 65-mile route was originally recommended by associates from Clear Channel Outdoor Advertising, a local company located in Cleveland. After personal examination of the suggested route, the final 50-mile route was selected by the VTTI research team so that it could be completed in a timely manner, while still allowing participants to be exposed to a mixture of interstate, downtown, and residential road segments. This loop contained a variety of billboards and other outdoor advertisements (e.g., on-premise signs, logo placards) as well as standard department of transportation (DOT) roadway signs. Figure 5 illustrates the final route used for data collection, while Table 3 lists the driving directions used for the experiment. The directions were mounted on the dashboard as illustrated in Figure 6.

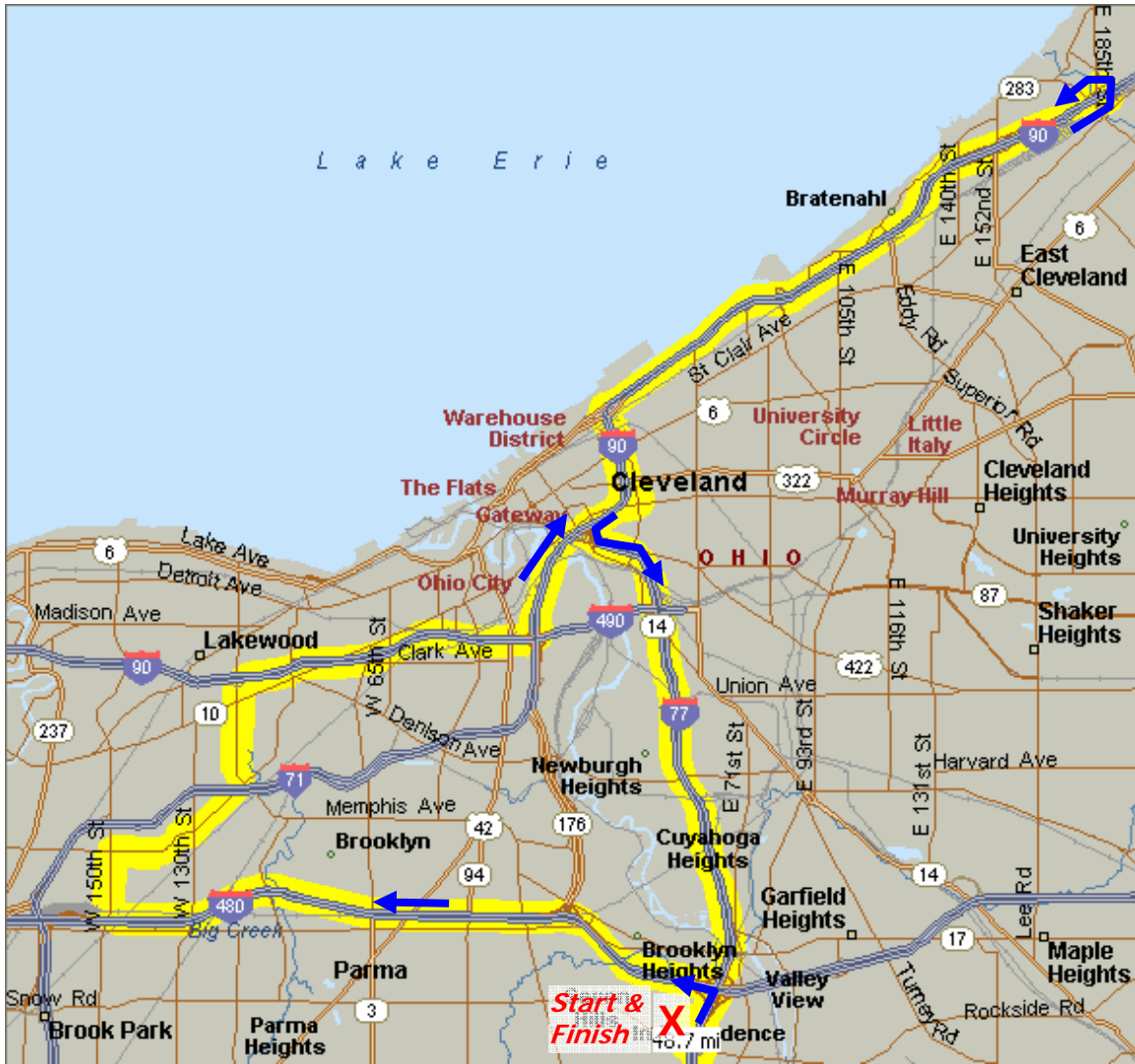

Figure 5. Map of 50-mile Daytime Loop Route in Cleveland, Ohio.

Table 3. Directions for 50-mile daytime route in Cleveland, OH.

<u>Directions</u>	<u>Trip Distance</u>	<u>Notes</u>
← Left out of Residence Inn onto W. Creek Rd.	0.0	
← Left onto Rockside Rd.	0.3	
➔ Right toward I-77 North	0.5	Go under overpass to I-77 N entrance
Left lane onto I-480 West / Toledo	1.1	
EXIT 12A Right Exit 12A, turn Right onto W. 150th St.	9.9	
➔ Right onto Puritas	10.9	Curves to Left, becomes Bellaire
← Left onto W. 117th	13.1	Just past entrance to I-71
➔ Right onto I-90 East / Cleveland	14.4	
EXIT 172A Right Exit 172-A, East 9th St.	20.1	Stay to Right
➔ Right onto Carnegie	20.4	
← Left onto East 30th St.	21.3	DODD Camera on far left corner
← Go 1 block, Left onto Prospect	21.4	
← Go 500 ft., Left onto I-90 East	21.5	
EXIT 182A Right Exit 182A, Right onto E. 185th St.	30.9	
Stay in Right Lane and get onto I-90 West to Downtown	31.2	Stay on 90 W when splits to left
EXIT 172A Take Right Exit 172A to I-77 South	41.2	
Follow I-77 South to Rockside Road exit	48.2	
EXIT 155 Take Exit 155 Rockside Road and Independence, turn Right onto Rockside Rd.	48.8	
➔ Turn Right onto W. Creek Rd.	48.9	
➔ Turn Right into Residence Inn parking lot	49.2	

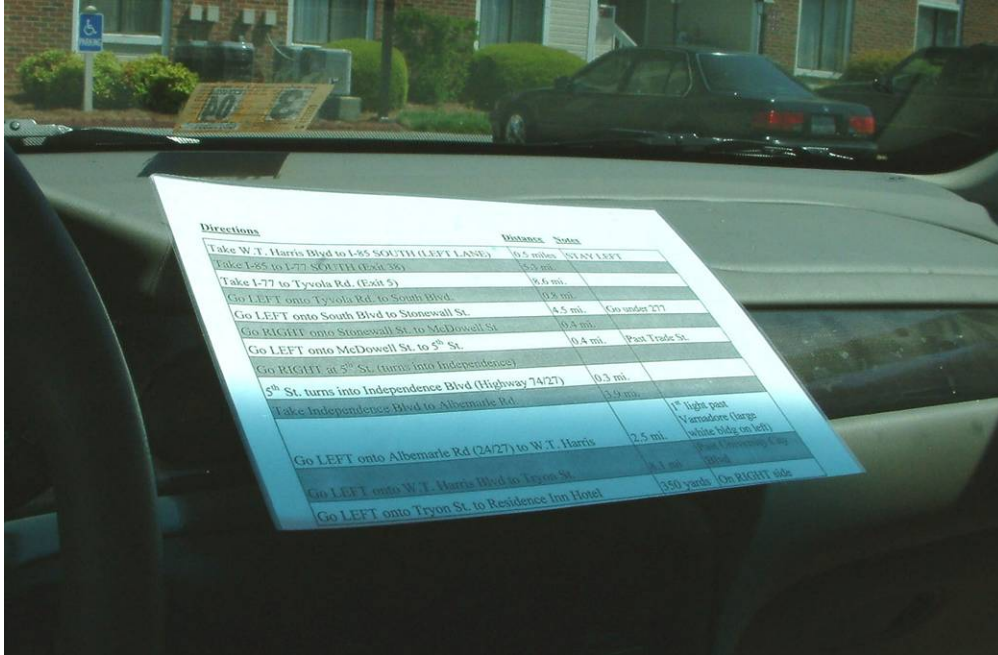

Figure 6. Directions mounted on dashboard of vehicle (this picture is from a previous experiment which used the same protocol and vehicle type).

Practice Route. A short, 1.5-mile practice route was also included. This route was driven prior to data collection on the 50-mile loop route. During the practice route, the experimenter rode as a passenger with the participant to make sure that the participant was familiar with the directions and the vehicle’s displays and controls. Table 4 lists the directions for the practice route, which was conducted on local streets near the hotel where the study began and ended.

Table 4. Directions for 1.5-mile Practice Route in Independence, Ohio.

<u>Directions</u>	<u>Trip Distance</u>	<u>Notes</u>
➡ Right out of Residence Inn onto W. Creek Rd.		
➡ Right onto Jefferson Dr.		
↻ Go around the traffic circle		
⬅ Left onto W. Creek Rd.		
➡ Right onto Patriot's Way		
Straight at Stop		Past Applebee's
⬅ Left into Parking lots, loop back onto Patriot's Way		
Straight at Stop		
⬅ Left onto West Creek Rd.		
➡ Right into Residence Inn parking lot	1.5 mi	

Vehicle

A 2002 Chevrolet Malibu was used in this study and is shown in Figure 7. The vehicle had an automatic transmission, an adjustable steering wheel, and other standard features.



Figure 7. Experimental Vehicle, 2002 Chevrolet Malibu.

Data Collection System

The vehicle was instrumented with a data collection system, including cameras, a computer, and sensors that continuously collected data. The system was activated approximately 2 min after the ignition was turned on and was deactivated when the driver turned it off. A video system with four cameras was used. Two cameras were mounted on the back side of the rear-view mirror--one facing forward left and the other facing forward right (Figure 8). This captured the forward views of the roadway as well as the sides where billboards and other objects were visible. The other two cameras captured the driver's face from two perspectives. One camera was mounted on the top left corner of the windshield near the A-pillar (Figure 9). The other camera was mounted just above the rear view mirror (Figure 10). Both faced the driver and captured head and eye movements. Since data reductionists needed to review all four video channels simultaneously, a quad-splitter was used to fuse the images. This produced a single, compartmentalized image such that each camera was presented in one of four locations (Figure 11). The quad splitter, computer, monitor, and keyboard were located in the trunk of the vehicle as shown in Figure 12. Finally, Figure 13 illustrates these components and shows how they interacted with sensors. Infrared illumination was used to provide adequate illumination for a smaller nighttime data collection effort, to be described later in the report.



Figure 8. Forward Facing Cameras Mounted Behind the Center Rear View Mirror.

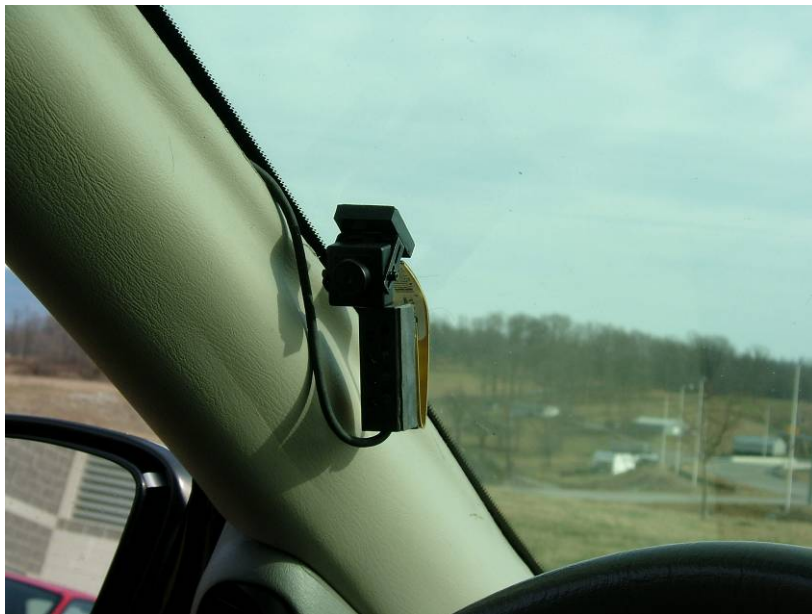

Figure 9. Driver Face Camera, Mounted near the left A-Pillar.



Figure 10. Driver Face Camera Mounted Above Rear View Mirror.

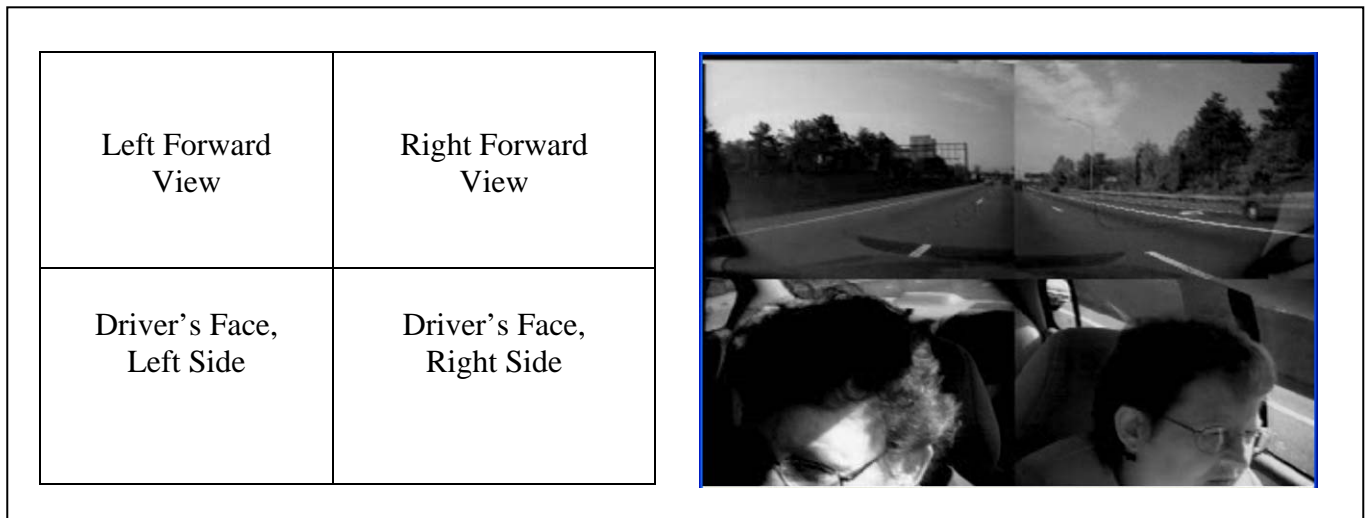

Figure 11. Diagram of Simultaneous Presentation of Four Camera Views.



Figure 12. Data Acquisition System Located in Trunk of Vehicle.

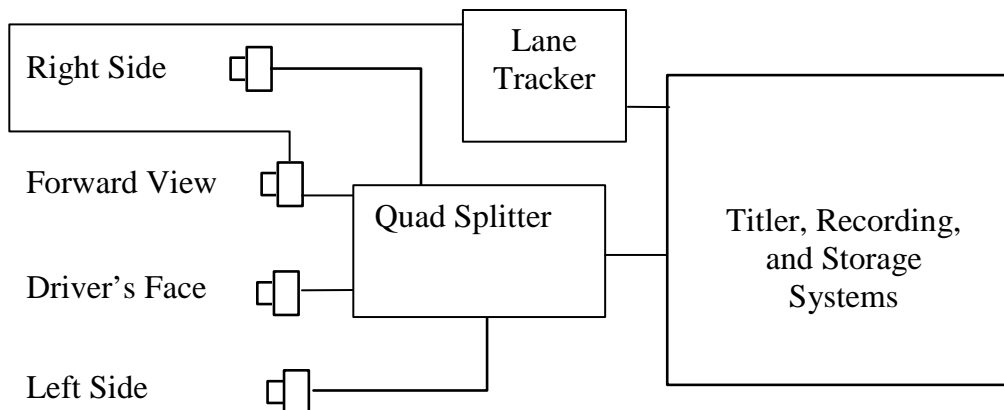

Figure 13. Components of the Data Collection System.

All video data were recorded at 30 Hz (30 frames per s), using MPEG 4 compression algorithms at a rate of 4 MB per minute. Driving performance data, including lane position and velocity, were collected at 10 Hz (10 times per s). The lane tracking system used fuzzy logic and statistical probabilities to detect lane edges in the forward camera view. Lane position was collected with a resolution of ± 2 inches from the center of the lane. Raw performance data, including lane position, velocity, and video data, were saved on the hard drive of a laptop computer and then backed up onto individual DVDs for each participant. After each trial, the experimenter reviewed the data to assure that the data collection system performed to specification.

Procedure

Participant Recruitment and Screening

Straight-text newspaper advertisements were placed in the *Cleveland Plain Dealer* (Figure 3) and flyers were posted in strategic locations in Cleveland, OH to solicit volunteer participants for the study. Respondents were instructed to contact the experimenter via email or by telephone. A telephone/email screening form (Appendix A) was used to collect general information on age, gender, medical, and driving history, familiarity with the route(s), and use of corrective lenses or sunglasses. A list of potential participants was compiled as screenings were completed, and participants who met all of the required criteria were then contacted to set up an appointment for participation. The participant met the experimenter on the appropriate date and time in the hotel lobby of the Residence Inn on West Creek Road, in Independence, OH (just south of Cleveland).

Experimental Protocol

Upon arrival, each participant presented a valid driver's license for the experimenter's inspection. Each participant then completed an informed consent form (Appendix B) and a health screening questionnaire (Appendix C). Participants also completed a vision test using a Snellen eye chart. Only participants with vision of 20/40 or better were eligible to participate.

Participants received an orientation (including the practice route), drove the 50-mile experimental route, completed a post-drive questionnaire (Appendix D), and received \$20/hr for their time. Most participants completed the experiment in less than two hours. All procedures for recruitment and data collection were approved by the Virginia Tech IRB, as required by federal and state law.

In all, 36 drivers were recruited for the full experiment. Another participant completed the experiment, but the data were not used because it rained during most of the session. Of the 36 drivers who completed the experiment, 3 repeated the experiment on a later date due to rain. That is, their initial data were not used and were replaced with the second driving session. The order in which participants were run in the experiment is shown in Table 5.

Table 5. Order of Participation (shown by Age and Gender).

Number	AgeGrp	Gender
1	O	M
2	O	M
3	Y	M
4	O	M
5	Y	F
6	Y	F
7	O	F
8	Y	F
9	O	F
10	Y	M
11	O	F
12	Y	M
13	O	M
14	O	M
15	Y	M
16	O	F
17	O	F
18	O	F
19	O	M
20	Y	F
21	Y	M
22	Y	F
23	Y	F
24	O	M
25	Y	F
26	O	F
27	O	M
28	Y	M
29	O	F
30	Y	F
31	Y	F
32	O	F
33	Y	M
34	Y	M
35	Y	M
36	Y	F

The informed consent form explained the general purpose of the experiment to the driver and obtained his/her permission to participate in the study. After the required paperwork was completed, the following script describing the experiment was read aloud to the participant:

Today we will have you drive a pre-determined loop route along major freeways and highways. The vehicle that you will be operating is specially equipped with instruments that collect information about your driving habits. The purpose of this

study is to collect information about the way people drive under normal circumstances, in order to improve driver safety. We want you to drive as you would if you were in your own vehicle and were driving, for example, to visit a friend, do an errand, or go to work. With this in mind, we will also want you to obey all typical traffic regulations as you normally would, including, but not limited to, posted speed limits, lane markings, and traffic control devices (such as stoplights).

I will be riding in the passenger seat during a 5-minute orientation drive. You are welcome to ask questions if necessary, as this orientation will help you become familiar with the vehicle and its controls. As always, our first priority is your safety. If at any time you feel uncomfortable please inform me and we can make any necessary adjustments or end the study early.

After the 5-minute orientation, I will exit the vehicle and have you drive the pre-determined route, which will bring you back to this location. This route will take about 1.5 hours. A map and written instructions will be provided for your reference, and I will also review the route with you before you depart. After the route is completed, I will debrief you and the session will be complete.

Do you have any questions I can answer at this time?

The experimenter then reviewed the map (Figure 5) and directions (Table 4) in detail. A laminated copy of the map was stored in the glove compartment for easy reference. A laminated copy of the directions was prominently displayed on the dashboard (Figure 6). A cellular telephone was also stored in the glove compartment for emergency use only.

The experimenter then oriented the participant to the vehicle, including adjustment of the seat, seat belt, mirrors, and steering wheel. Displays and controls were also reviewed, including a review of the map, directions, and cell phone operation instructions. The participant then drove the 5-minute orientation route, with verbal reminders provided by the experimenter when required. After the orientation route was completed, the experimenter checked the data, reminded the participant to drive as he/she normally would, and then returned to the hotel. The participant drove the 50-mile loop route, which eventually brought him/her back to the hotel.

After the experiment, in-vehicle eyeglance calibration was completed in the hotel parking lot. With the vehicle parked, the experimenter sat in the passenger seat and provided verbal instructions. The protocol included having the participant sit as if driving, while alternating 3-second glances to various locations with a default forward glance location. The glances included left blind spot, left window, left mirror, left forward, forward, right forward, right mirror, right window, right blind spot, rear view mirror, instrument panel (speedometer), and climate and radio controls.

After the eyeglance calibration, the participant and the experimenter returned to the hotel lobby, where the post-drive questionnaire was completed (Appendix D). The experimenter then reviewed the questionnaire to make sure that all of the answers were legible. Item #3, "Please check the top five items that most caught your attention during your drive," included a "Billboards" option (among a list of 18 possible items). If the experimenter noticed that

“Billboards” had been marked, she asked about every checked item in an attempt to discover the details as to what caught their attention. For the billboard item specifically, the experimenter noted what aspect of the billboard caught the participant’s attention, without conveying the importance of that particular topic. Payment was then issued to the driver at a rate of \$20 per hour, (2 hours in most cases, for a total of \$40) and a payment log was signed to verify that funds were received. At no time was the participant made aware that this experiment was related to driving behavior regarding billboards or other roadside items.

Data for each participant were briefly reviewed to verify that all the cameras were operating correctly and that data had been recorded. Data and video files were then transferred from the data collection system’s computer to a portable laptop computer. Each participant’s data were copied onto a separate DVD as a second back-up measure. The results from the post-drive questionnaire were then entered into an Excel spreadsheet for later processing.

Data Reduction

Analyst Training

Two data analysts worked on this project under the supervision of the principal investigator. All analysts were experienced in video data reduction prior to this project. Training began with a 2-hour session in which the user manual was reviewed and the analysis software was demonstrated by the experimenter. Relevant functions were shown, and the process of how to load the map and associated GPS coordinates was explained. Prior to actual data analysis, each analyst spent an additional eight hours mastering eyegance direction determination and spreadsheet use. This period included time with an experienced analyst present. A large part of that time was dedicated to establishing inter-analyst reliability by comparing judgments and modifying techniques until all analysts’ independent determinations matched. Throughout the entire analysis effort, at least one experienced analyst was available at all times to answer any questions or review particular cases as needed. “Spot checks” were performed throughout the data reduction process, with input provided as needed to maintain a high level of consistency. Robust reliability was further assured by ascertaining that each analyst recorded a portion of the data from each participant (i.e., a portion of the data for each of the 36 participants was analyzed by each analyst). As events were completed, a written record was created with the analyst’s initials and date of completion.

Software

This section outlines the data reduction software program developed to analyze digital billboard, conventional billboard, comparison, and baseline events. The software, currently called DART (Data Analysis and Reduction Tools), was originally developed by software engineers at VTTI for a large-scale naturalistic driving study known as the 100 Car Study (Dingus, Klauer, Neale, Petersen, Lee, et al., 2006). This program integrates Microsoft MapPoint 2003 using GPS data for billboard, comparison, and baseline site locations with the data obtained from the multiple sensors in the test vehicle via a graphical interface. A total of 36 files (representing the route driven for each participant) were analyzed. After a file was opened, the software presented the analyst with the relevant windows required for data identification and reduction. The MapPoint

application allowed the analyst to view a map of the Cleveland, OH area, showing the relationship between the site and the roads, so that video could be compared with GPS data during site identification and eyeglance analysis. The map illustrated the route and the location of the vehicle, which was represented by a green vehicle icon that moved as the event was played. This map served solely as a visual display and could not be manipulated.

Procedure

Data reduction was performed by the two analysts for each of the 36 data files. This occurred in three steps: software preparation, event identification, and eyeglance analysis. Analysts were blind as to which event type was being analyzed (in other words, they knew the event only by its number, and did not know what type of event was contained in that segment of data). This was done to insure impartiality in this aspect of the data reduction (event identification and eyeglance reduction were the only two aspects of data analysis which had a subjective component; this was compensated for by re-doing 10% of the events and calculating inter-rater reliability).

Event Identification

Analysts first used the DART software to identify the locations of interest. The GPS coordinates for each location were entered into a master map. Each file was then opened and the DART software suggested the correct point for each location of interest based on the master GPS list. The analyst compared the forward view shown in the video with a master file of forward views and adjusted the event timing slightly if necessary to make sure the forward views were the same for every participant (thus providing a common geographic point of reference for each event analyzed). The end of an event was defined as the sync number (time reference) at which the test vehicle passed the site, and the event's beginning was calculated to be eight seconds before the end point. Identification of the end point thus combined two methods: the GPS data was used to align the vehicle directly in conjunction with the site, and then the video was used to visually confirm accurate GPS positioning using comparison to a master file of forward views.

Eyeglance Analysis

Once all of the events were correctly identified and stored in the database, the analysts conducted the eyeglance analysis for each event. The first step in eyeglance analysis was familiarization with the participant's individual glance patterns by means of a glance location calibration video, during which participants looked at specific places according to a set script. Analysts referred often to the calibration file collected for each participant to make sure that the glance locations were being coded correctly.

As described in the procedures section, eye calibration was conducted *after* data collection was complete, in order to serve as a record of how a particular driver's glance to particular location is shown in video. Analysts reviewed these records in order to become familiar with the

participant's glance style. The analyst was thus able to conduct the glance analysis according to each participant's glance style. Glances were coded according to the following abbreviations:

- F - Forward
- RF - Right Forward
- LF - Left Forward
- RVM - Rear View Mirror
- OX - Outer eXterior, including side mirrors, side windows, blind spot, etc.
- DIR – glances toward the experimental route DIREctions
- OINT - Other INTerior, including speedometer, sun visor, cell phone, etc.

Analysts reviewed events from beginning to end, one tenth of a second at a time, determining the direction of glance for every tenth of a second for the eight-second duration of the event. New glances were recorded as the sync number at which the participant's glance *rested* in a new location. Transition time to the new location was included in the glance location the driver was moving *away* from. The DART program automatically calculated the duration of each glance. Summary information for each event included the number of glances, average glance duration, number of glances in each direction, and the average duration of glances in each direction. The final inter-rater reliability for the eyeglance reduction process was 96.5%, which is considered quite good. Approximately 5% of the daytime events were analyzed by both raters independently, resulting in 8,084 individual glance locations, each lasting 0.1 s. The agreement between raters for each location was compared; the 96.5% reliability means that the raters were in agreement for 7,804 glance locations.

Final Reduced Data Set

With 36 participants and 44 sites, there were 1,584 events available for analysis from approximately 63 hours of data collection. A small amount of data was lost due to cell phone use, sensor outages, sun angle, and vehicle stoppages, leaving 1,540 events for eyeglance analyses. Altogether, 124,740 video frames were analyzed (1,540 events x 81 frames/event) and 8,678 individual glances were identified. The speed data was filtered to remove events as described above, and then further filtered to remove events in which the maximum speed failed to read 20 mph or the minimum speed failed to reach 15 mph, leaving 1,494 events in this dataset, with 121,014 data points for speed. The lane position dataset was further filtered to remove events indicating a possible lane change or lane position sensor failure (often due to poor lane markings). After filtering, there were 1,188 events remaining in the lane position dataset, with 96,228 data points.

Statistical Analysis





Descriptive statistics were calculated using Excel. All other statistical analyses were conducted using SAS statistical software. The analysis of variance (ANOVA) statistical technique was used; in SAS this was accomplished by means of the general linear model (GLM) procedure. Where significant differences were found, and there were more than two levels of the independent variable, a post-hoc analysis was run using the Least Squares Difference procedure

in SAS to determine which levels were significantly different from which other levels. (For independent variables with just two levels that differ significantly, a simple examination of the means will demonstrate which level is significantly greater than the other.)

Nighttime Study

A smaller exploratory study was also conducted at nighttime using an abbreviated route that avoided some of the downtown streets. Given that the digital signs being studied were intrinsically illuminated, this was felt to be an important first step in determining whether there are driver performance differences in the presence of these signs under different levels of ambient illumination. All of the nighttime drivers had previously driven the route during the daytime and were thus somewhat familiar with the route (so were unlikely to get lost or go off route). The nighttime route directions are shown in Table 6, while the order of participation is shown in Table 7 (12 of the 36 drivers returned for the nighttime experiment). The nighttime route map is shown in Figure 14.

Table 6. Nighttime Driving Directions.

<u>Directions</u>	<u>Trip Distance</u>	<u>Notes</u>
← Left out of Residence Inn onto W. Creek Rd.	0.0	
← Left onto Rockside Rd.	0.3	
➡ Right toward I-77 North	0.5	Go under overpass to I-77 N entrance
Left lane onto I-480 West / Toledo	1.1	
 Right Exit 12A, turn Right onto W. 150th St.	9.9	
➡ Right onto Puritas	10.9	Curves to Left, becomes Bellaire
← Left onto W. 117th	13.1	Just past entrance to I-71
➡ Right onto I-90 East / Cleveland	14.4	
 Right Exit 182A, Right onto E. 185th St.	30.1	
Stay in Right Lane and get onto I-90 West to Downtown	30.4	Stay on 90 W when splits to left
 Take Right Exit 172A to I-77 South	40.3	
Follow I-77 South to Rockside Road exit	47.3	
 Take Exit 155 Rockside Road and Independence, turn Right onto Rockside Rd.	47.9	
➡ Turn Right onto W. Creek Rd.	48.0	
➡ Turn Right into Residence Inn parking lot	48.3	

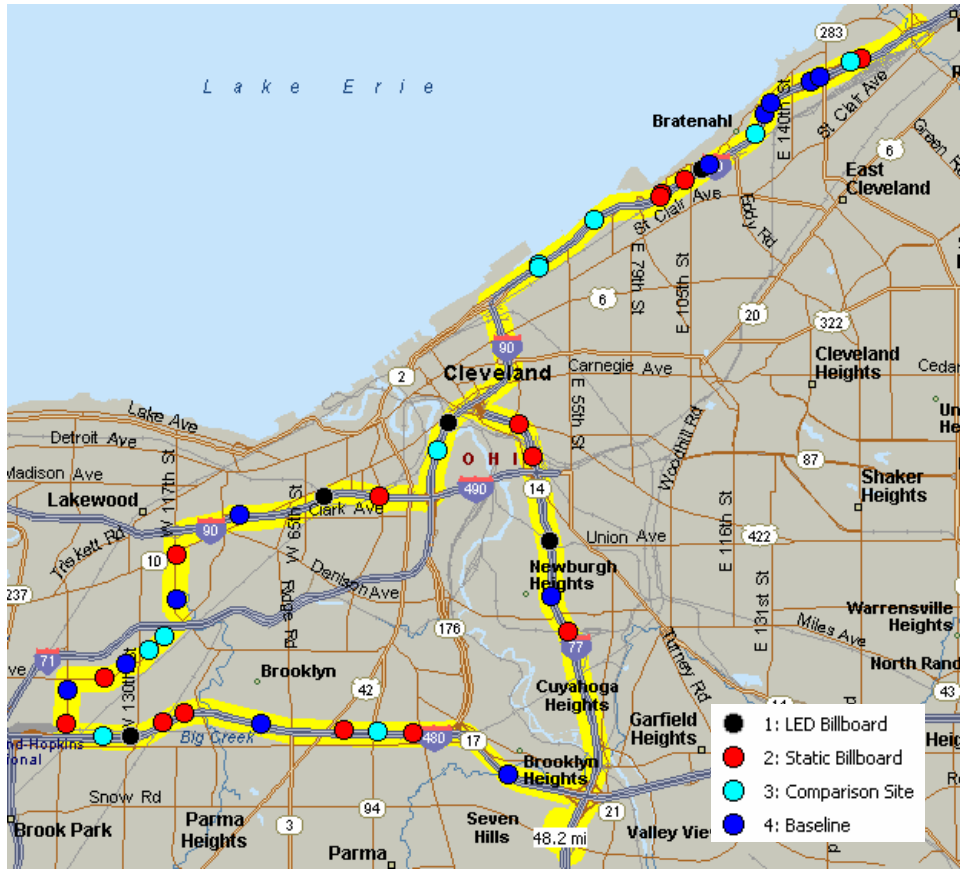

Figure 14. Map Illustrating Nighttime Route with Digital Billboards (black), Conventional Billboards (red), Comparison Sites (aqua blue), and Baseline Sites (blue).

Table 7. Nighttime order of participation.

Number	Age group	Gender
1	Younger	Female
2	Older	Male
3	Older	Female
4	Older	Female
5	Younger	Female
6	Older	Male
7	Younger	Male
8	Younger	Male
9	Older	Female
10	Older	Male
11	Younger	Male
12	Younger	Female

With 12 participants and 40 sites, there were 480 events available for analysis from approximately 42 hours of data collection. A small amount of data was lost due to cell phone use, sensor outages, and vehicle stoppages, leaving 470 events for eyegance analyses. Altogether, 38,070 video frames were analyzed (470 events x 81 frames/event) and 2,335 individual glances were identified. The speed data was filtered to remove events as described above, and then further filtered to remove events in which the maximum speed failed to read 20 mph or the minimum speed failed to reach 15 mph, leaving 456 events in this dataset, with 36,936 data points for speed. The lane position dataset was further filtered to remove events indicating a possible lane change or lane position sensor failure (often due to poor lane markings). After filtering, there were 411 events remaining in the lane position dataset, with 33,291 data points. Because the nighttime study was exploratory in nature with fewer data points, these data are shown descriptively, but were not analyzed statistically (due to lack of statistical power).

RESULTS

Post-Drive Questionnaire – Daytime Results

Participants completed the post-drive questionnaire (Appendix D) after they returned from driving the daytime driving route as well as the nighttime route. The questionnaire gathered information such as route familiarity and items noticed while driving; it also collected demographic and personal information, including education level, marital status, ethnicity, and income. The questionnaire was the same one used by Lee et al. (2004) in the previous study using similar methods. The following sections summarize all questionnaire results for the daytime drivers, followed by a section describing the results for the nighttime drivers.

Demographics Overview

In terms of demographics, the average age was 28 years for younger drivers and 59 years for older drivers. The sample of drivers was quite diverse in terms of education level, marital status, and income. All drivers lived and worked in the Cleveland, OH area and were familiar with some or most of the route. The following sections provide details for relevant information about the sample of drivers. Table 8 presents these findings as well.

Age. The sample of 36 drivers ranged in age from 18 to 71 years old. The mean age of all participants was 43.3 years (SD = 16.7). The younger drivers ranged in age from 18 to 35 years old, with a mean of 27.9 years (SD = 6.0). The older drivers ranged in age from 50 to 71 years old, with a mean of 58.7 years (SD = 6.1).

Education Level. Participants were surveyed regarding the highest education level they had completed. The number of responses and equivalent number of years were used to calculate the product. This was used to calculate the mean education level for the sample by dividing the total number of years completed by the number of participants (482/36). The average was 13.4 years of education completed (equivalent to high school plus a year and a half of college). Most of the participants had finished high school, but few had attended college.

Marital Status. Half of the participants were married, while 28% reported that they were single and 17% were divorced. Two individuals (5.6%) indicated that they were separated.

Ethnicity. Most participants were European (Caucasian/White) with only one participant identifying herself as African American.

Income. The income level with the most participants was the group earning between \$25,000 and \$49,000 per year (16 participants or 44%).

Table 8. Summary of Demographic Results for All Daytime Participants.

CATEGORY	LEVELS			
Age (mean)	Younger Drivers	Older Drivers	All Drivers	
	27.9 years	58.7 years	43.3 years	
Education Level	High Sch.	2-Yr Deg.	B.A./B.S.	
	52.8%	25.0%	22.2%	
Marital Status	Single	Married	Divorced	Separated
	27.8%	50.0%	16.7%	5.6%
Ethnicity	African American	European		
	2.8%	97.2%		
Income Level	\$0-24K	\$25-49K	\$50-74K	>\$100K
	33.3%	44.4%	19.4%	2.8%

Route Familiarity

Route familiarity was assessed by three items in the questionnaire. Specific topics addressed were: location of work, location of home, and frequency of driving on roads in the experimental route (defined as familiarity). Table 9 presents the route familiarity findings.

Living and Working Location. All drivers reported that they were familiar with the Cleveland, OH area and had driven on the interstates and surface roads included in the route. All of the participants lived in the Cleveland area, and those who were employed also worked in the area. Cleveland proper, Parma, and Independence were the most common locations where participants lived and worked, with 39% of participants reporting that that they both lived and worked in one of these three areas (Independence and Parma are adjacent suburbs of Cleveland).

Familiarity. Route familiarity was also evaluated in terms of five route segments that represented various types of driving (i.e., various segments of interstate and downtown Cleveland). Drivers were asked to indicate if they were either “familiar” (driven at least once a week) or “not familiar” (driven less than one time a week) with each segment. In some cases, participants inquired about this question item, indicating (verbally) that, although they were quite familiar with certain areas, they may not drive on them every week. Nonetheless, the results indicated that overall, drivers were familiar with the route, particularly I-480 W between I-77 and W150th (83% were familiar with this segment as shown in Table 9).

Table 9. Route Segment Familiarity for All Daytime Participants.

	Route Segment				
%	I-480W between I- 77 and W150th	W.130th - Bellaire - W.117th	I-90 between 9th and 185th	Carnegie Ave.	I-77 between I- 90 and Rockside
Familiar	83%	42%	64%	67%	72%

Overview of What Drivers Noticed

Drivers primarily noticed items such as traffic and other drivers, road or highway signs, and road construction. Fifteen of 36 drivers (42%) marked “billboards” as one of the top 5 items (out of 18 items) that caught their attention during the drive. Participants engaged in a variety of activities while driving; listening to the radio or CD player and using the cell phone were the most prevalent. At no point was it apparent that any participant knew the specific purpose of the study; all responses indicated that drivers believed the study was related to observing drivers in a natural driving situation, which was also true. The following sub-sections describe findings in more detail, with tables illustrating drivers’ responses.

Attention Getters. Participants were asked to indicate “the top five items that most caught your attention during your drive.” Over 50% of drivers indicated that they paid attention to traffic, road signs, exit signs, and other drivers. The top 9 items (out of 18 listed) are shown in Figure 15. For those drivers who indicated “billboard” as one of the items that caught their attention, the experimenter asked them to verbally expand upon all items; however, none of these drivers made any additional comments about billboards except that they caught their attention. Three drivers (8%) mentioned billboard under a separate question regarding the single most memorable part of the drive. Their comments were “The lighted billboards,” “Ridiculous billboards,” and “The light up billboards.” A fourth driver mentioned “Markers and signs” but did not elaborate further. Even in the daytime, the digital billboards appeared to have been noticeably different from conventional billboards and appeared to attract a certain amount of attention.

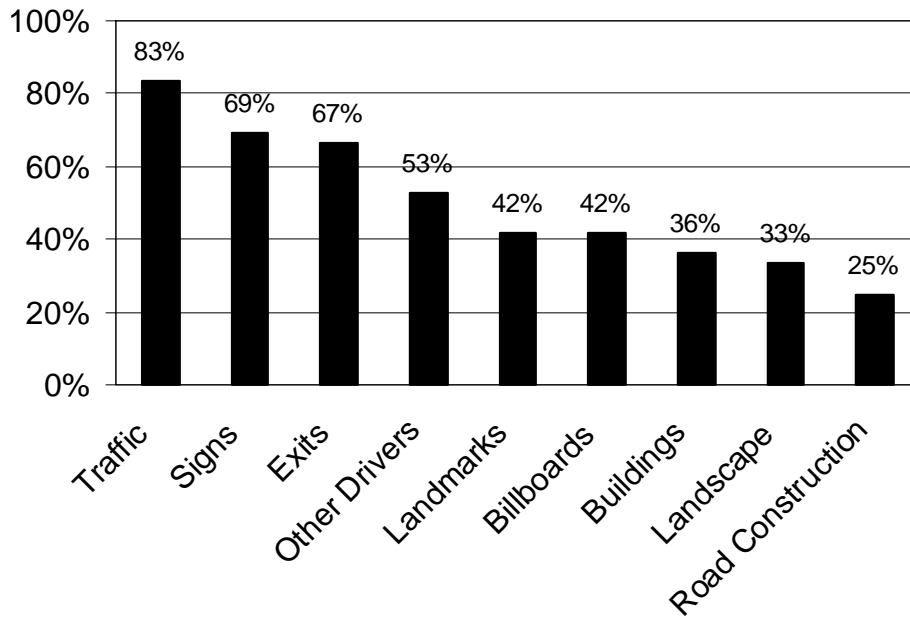

Figure 15. Top Daytime Attention Getters (top nine of eighteen possible).

Most Memorable. Participants were asked “What was most memorable about the drive?” This was an open-ended question, so the comments varied. For ease of categorization, similar comments were grouped where possible. There were 35 comments. Over 68% of the comments were related to construction, weather/view, the experimental vehicle, or traffic, as presented in Table 10.

Table 10. Number and Percent of Comments for Daytime Participants for the Question: “What was most memorable about the drive? For example, were there any objects that stood out?”

Comment Categories	Number of Comments	Percent of Comments
Other Vehicles/Traffic	7	17.5%
New Route/feature about route	6	15.0%
Lake	5	12.5%
Weather/View	4	10.0%
Test Vehicle	3	7.5%
Digital Billboards/Billboards/signs	3	7.5%
Neighborhoods	3	7.5%
Rough Road	3	7.5%
Relaxing/Positive trip	2	5.0%
Construction	1	2.5%
Near accident/Accident	1	2.5%
Sports Arena	1	2.5%

What Bothers You? Participants were asked, “What bothers you about other drivers?” This was an open-ended question, so the comments varied. For ease of categorization, similar comments were grouped where possible. A total of 30 comments were made. The large majority of the comments were related to aggressive maneuvers or questionable driving behavior such as tailgating, being cut off, not using turn signals, or driving slowly in the fast lane (Table 11).

Table 11. Number and Percent of Comments for Daytime Participants in Response to the Question: “Does anything about other drivers bother you? If so, please briefly describe.”

Comment Category	Number of Comments	Percent of Comments
Tailgating	7	23.3%
Cut off	6	20.0%
No signal	5	16.7%
Speeding	3	10.0%
Aggressive	3	10.0%
Slow in fast lane	3	10.0%
Cell phone talking	1	3.3%
Drivers who don't pay attention	1	3.3%
Inability to adjust to conditions	1	3.3%

Other Activities. Participants were asked, “What other activities do you engage in while driving?” Again, this was open-ended and the comments varied, but similar comments were grouped where possible. There were 72 comments in all. Listening to the radio or CDs was the largest single activity, making up over 26% of the comments. Using the cell phone was also common (15%). Other activities included singing or talking, drinking, smoking cigarettes, and eating, as presented in Table 12.

Table 12. Number and Percent of Comments for Daytime Participants in Response to the Question: “What other activities do you typically engage in while driving?”

Comment Categories	Number of Comments	Percent of Comments
Listen to radio/CDs	21	38.9%
Cell phone	11	20.4%
Smoking	4	7.4%
Eating	4	7.4%
Drinking	3	5.6%
Talk w/others	3	5.6%
Adjust radio/CDs	2	3.7%
Driving/steering	2	3.7%
Adjust AC/windows	1	1.9%
Look for something	1	1.9%
Homework	1	1.9%
Read directions/map	1	1.9%

Other questions asked participants for additional input about the written directions and the purpose of the study. Substantively relevant participant responses included three separate suggestions relating to conducting a driving study with passengers or children, the effect of video cameras on driving behavior, and the statement that “driving in my own car would be more ‘normal.’ ” While no one reported problems with the directions, three drivers did get off-route at one point during their trip; however, very few data points were missed. Drivers were also queried as to their recollection of the purpose of the study; all responses were within the scope of what they had been told verbally and in the informed consent form.

Post-Drive Questionnaire – Nighttime Results

Age

The sample of 12 nighttime drivers ranged in age from 25 to 62 years old and consisted of drivers who had recently performed the daytime portion of the experiment. As for the main experiment, the participant pool was balanced for age and gender. The mean age of the nighttime participants was 44.5 years ($SD = 14.0$). The younger drivers ranged in age from 25 to 35 years old, with a mean of 31.5 years ($SD = 4.1$). The older drivers ranged in age from 54 to 62 years old, with a mean of 57.5 years ($SD = 3.3$). The demographics for these 12 drivers are summarized in Table 13.

Table 13. Summary of Demographic Results for All Nighttime Participants.

CATEGORY	LEVELS		
	Age (mean)	Younger Drivers	Older Drivers
	31.5 years	57.5 years	44.5 years
Education Level	High Sch.	2-Yr Deg.	B.A./B.S.
	58.3%	25.0%	16.7%
Marital Status	Single	Married	Divorced
	8.3%	66.7%	25.0%
Ethnicity	European		
	100.0%		
Income Level	\$0-24K	\$25-49K	\$50-74K
	16.7%	41.7%	41.7%

Route Familiarity

Route familiarity was assessed by three items in the questionnaire. Specific topics addressed were: location of work, location of home, and frequency of driving on roads in the experimental route (defined as familiarity). As before, all nighttime drivers lived and worked in the Cleveland, OH area. Route familiarity was also evaluated in terms of five route segments that represented various types of driving (i.e., various segments of interstate). Drivers were asked to indicate if they were either “familiar” (driven at least once a week) or “not familiar” (driven less than one time a week) with each segment. Table 14 presents the route familiarity findings.

Table 14. Route Segment Familiarity for All Nighttime Participants.

	Route Segment				
		I-480W between I-77 and W150th	W.130th - Bellaire - W.117th	I-90 between 9th and 185th	Carnegie Ave.
% Familiar	75%	42%	58%	58%	50%

Attention Getters

Participants were asked to indicate “the top five items that most caught your attention during your drive.” Over 50% of drivers indicated that they paid attention to traffic, road signs, billboards, and exits. Figure 16 shows the top nine nighttime attention getters. For those drivers who indicated “billboard” as one of the items that caught their attention, the experimenter asked them to verbally expand upon all items, but no one made any remarks relevant to billboards. However, 3 of the 12 nighttime drivers (25%) noted billboards as being the single most memorable thing about the drive. One person just said “Billboards,” another said “I saw a billboard that changed and I wished it hadn't because I wanted to read the previous message,” and a third said “One billboard.” This is much higher than the 8% who mentioned billboards as

being most memorable during the daytime, and may be a reflection of the nature of the digital billboards.

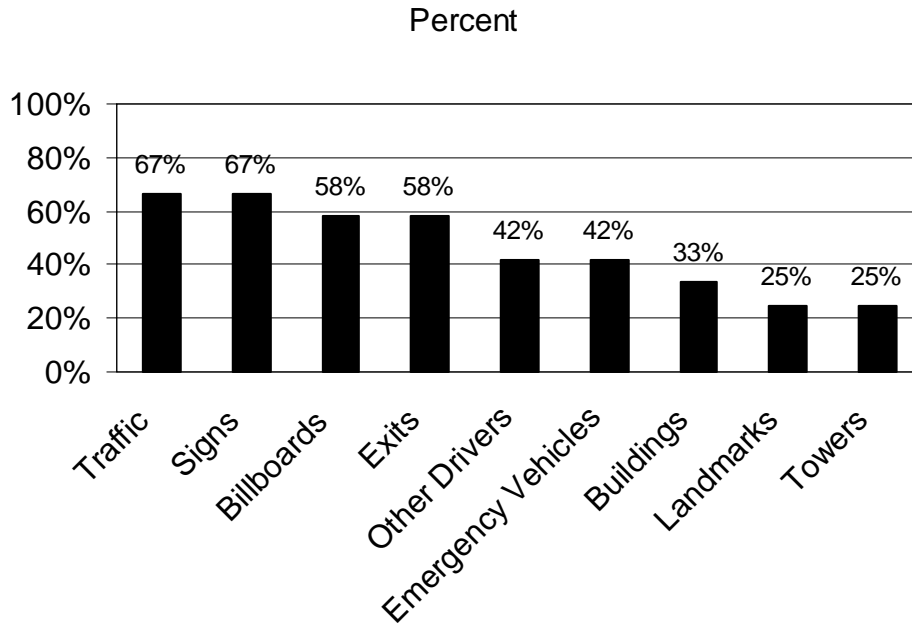

Figure 16. Top Nighttime Attention Getters (top nine of eighteen possible).

Most Memorable

Participants were asked “What was most memorable about the drive?” This was an open-ended question, so the comments varied. For ease of categorization, similar comments were grouped where possible. There were nine comments from the 12 nighttime drivers. As mentioned, three comments concerned billboards, while other common answers included the views and other vehicles and traffic, as presented in Table 15. The drivers had previously answered the general questions regarding “What bothers you about other drivers?” and “What other activities do you engage in while driving?” during their daytime session, so these were not asked again here. Likewise, the responses to “What is the purpose of this study?” were similar to what the same participants had said during the daytime session; all responses were within the scope of what they had been told verbally and in the informed consent form.

Table 15. Number and Percent of Comments for Nighttime Participants in Response to the Question: “What was most memorable about the drive? For example, were there any objects that stood out?”

Comment Categories	Frequency
Digital Billboards/Billboards	3
View	2
Other Vehicles/Traffic	2
Positive trip	1
Personal condition while driving	1

Driving Performance Results – Daytime

Event Type

Eyeglance Results. With regard to eyeglance behavior, there were six questions of interest, each of which will be discussed in turn:

1. Does eyes-on-road percent (looking straight forward) vary in the presence of different event types?
2. Is there a more active glance pattern in the presence of certain event types (as measured by the number of individual glances to any location during the eight seconds of the event)?
3. For events on the left side of the road, are there more glances in the left forward direction for certain event types?
4. For events on the right side of the road, are there more glances in the right forward direction for certain event types?
5. For events on the left side of the road, does the mean single glance time in the left forward direction vary according to event type?
6. For events on the right side of the road, does the mean single glance time in the right forward direction vary according to event type?
7. Are longer glances (longer than 1.6 s) associated more with any of the event types?

Question 1 (Does eyes-on-road percent (looking straight forward) vary in the presence of different event types?) was answered by examining the amount of time spend looking straight forward in the course of an event, and dividing it by 8 s to obtain the percentage of time the driver was looking forward. As shown in Figure 17, this ranged between 70% and 75% for the various event types, with baseline, digital billboard, and conventional billboard being close to equal. Statistical analysis showed that this measure did vary across event types ($F_{3,96} = 11.62$, $p < 0.0001$, using an α of 0.05 as a criterion, as is standard for studies of this type). The comparison events had significantly less eyes-on-road percent than did the other event types, which did not vary from one another.

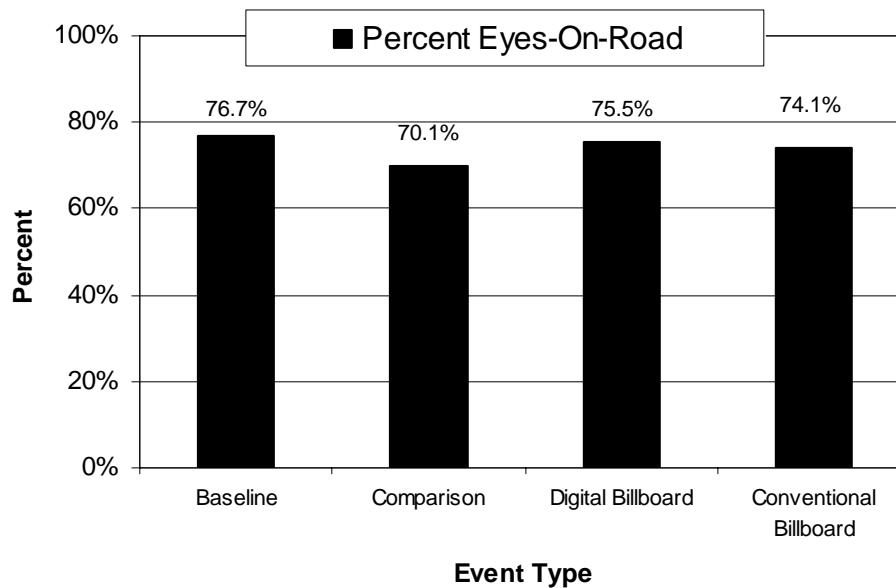

Figure 17. Percent Eyes-on-Road Time for the Four Event Types. (Comparison events were significantly lower than the other three event types, which did not differ from one another).

Question 2 (Is there a more active glance pattern in the presence of certain event types?) was measured by examining the number of individual glances to any location during the eight seconds of the event. A higher mean number of glances during the eight seconds indicated a more active scanning pattern. As shown in Figure 18, there were very few differences in the overall glance activity. The statistical analysis verified this observation, showing no significant differences between event types ($F_{3,96} = 1.78, p = 0.1564$).

Questions 1 and 2 were aimed at the larger question of whether overall driver eyeglance behavior changed in the presence of certain event types. In other words, did driver total time looking forward change in the presence of certain event types, and did drivers exhibit a more active glance pattern for certain event types? Except for lower eyes-on-road time for comparison events, there were no observed differences in overall eyeglance patterns. The next four questions are concerned with the specific eyeglance patterns that might be expected to occur if drivers were allocating more visual attention to specific objects located on the side of the road.

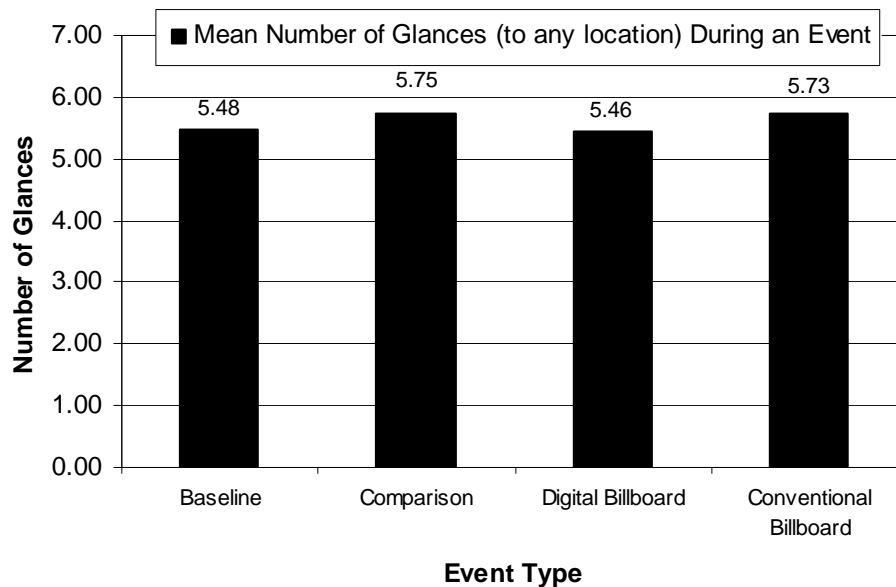

Figure 18. Mean Number of Glances to Any Location During an Event. (There were no significant differences between event types.)

Question 3 (For events on the left side of the road, are there more glances in the left forward direction for certain event types?) was aimed at the question of whether the presence of a site of interest on the side of the road was related to a greater number of glances in that direction. All baseline events were included in this analysis since these events were considered to have been located on both sides of the road. As can be seen in Figure 19, digital billboards to the left side of the road did garner a larger number of left forward glances during the eight seconds than did any of the other event types. However, statistical analysis showed that these differences were not significant ($F_{3, 73} = 1.49, p = 0.2244$).

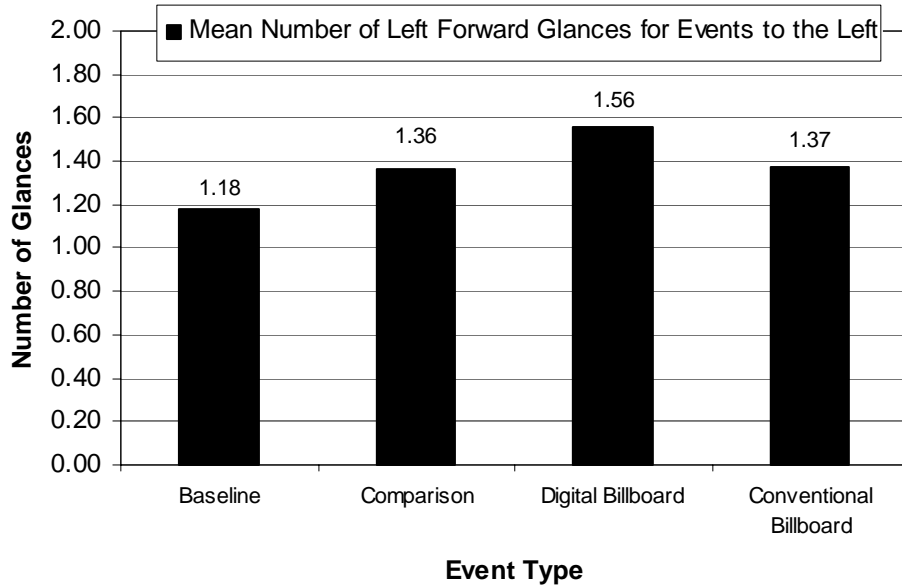

Figure 19. Mean Number of Left Forward Glances for Events on the Left Side of the Road. (There were no significant differences between event types.)

Question 4 (For events on the right side of the road, are there more glances in the right forward direction for certain event types?) was similar in intent, but used events on the right side of the road and right forward glances. Again, all baseline events were included in this analysis since these events were considered to have been located on both sides of the road. As can be seen in Figure 20, there appeared to be little difference in the number of right forward glances across event types. Statistical analysis showed that the observed differences were not significant ($F_{3,77} = 0.29, p = 0.8353$).

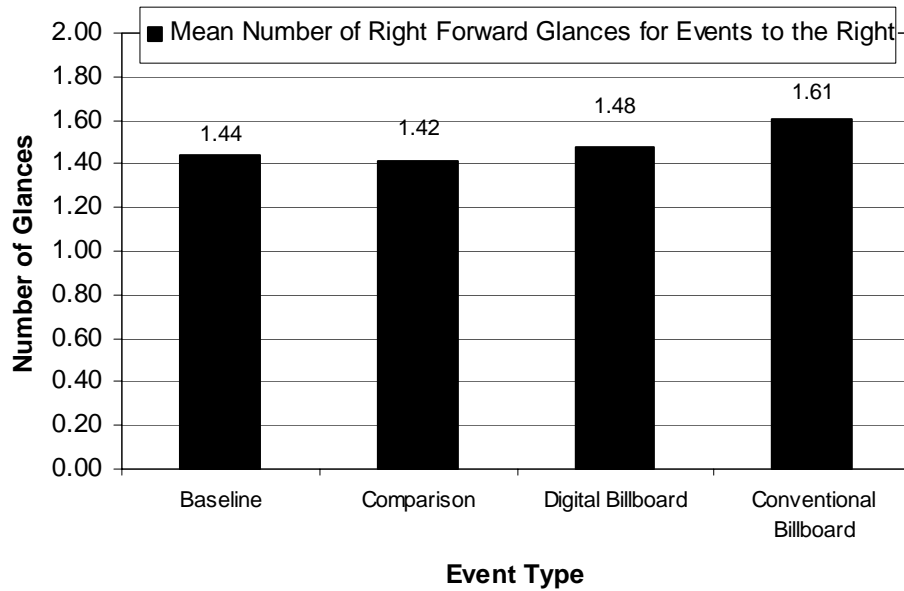

Figure 20. Mean Number of Right Forward Glances for Events on the Right Side of the Road. (None of the observed differences were significant.)

Question 5 (For events on the left side of the road, does the mean single glance time in the left forward direction vary according to event type?) was measured by examining the mean single glance time for left forward glances. Longer glances in the left forward direction for events to the left could indicate that the driver is paying greater visual attention to the event. Figure 21 shows that the digital billboard and comparison event types had longer mean single glance times than did baseline or conventional billboard events. Statistical analysis showed that these differences were significant ($F_{3,73} = 3.59, p = 0.0176$). Post hoc analysis showed that the digital billboards to the left had significantly longer left forward glances than did conventional billboards or baseline sites, but that they did not differ from comparison sites. Comparison sites differed from baseline sites, but not from conventional billboard sites, and conventional billboards and baseline sites did not differ from one another.

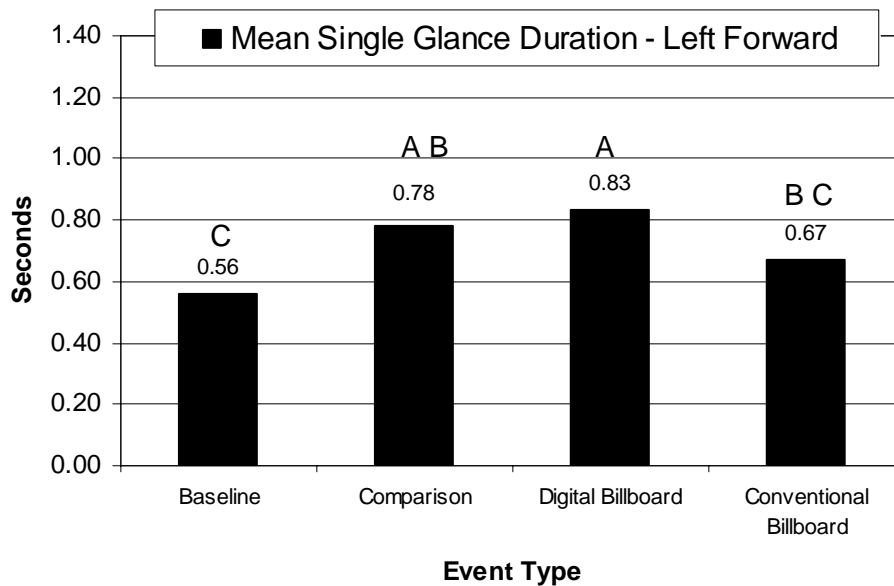

Figure 21. Mean Single Glance Time for Left Forward Glances for Events on the Left Side of the Road. (Data points with a shared letter do not differ significantly from one another.)

Question 6 (For events on the right side of the road, does the mean single glance time in the right forward direction vary according to event type?) was similar to Question 5 in approach, except that it examined right forward glances and events to the right. Statistical analysis showed that the observed differences were significant ($F_{3,77} = 3.73, p = 0.0147$). Post-hoc tests showed that digital billboards located on the right had significantly longer glance times to the right than did either baseline events or conventional billboards, but did not differ significantly from comparison events. Comparison events had longer glance times than did baseline events, but did not differ significantly from conventional billboards. Conventional billboards also had significantly longer glances than did baseline events.

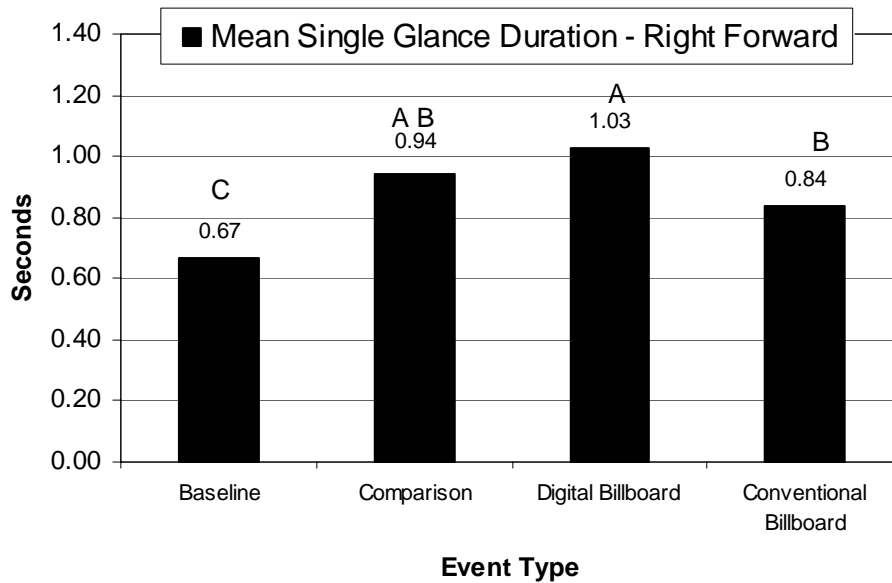

Figure 22. Mean Single Glance Time for Right Forward Glances for Events on the Right Side of the Road. (Data points with a shared letter do not differ significantly from one another.)

Question 7 (Are longer glances (longer than 1.6 s) associated more with any of the event types?) follows an approach provided by Horrey and Wickens (2007), who suggest analyzing the tails of the distributions whenever eyeglance analysis is performed. Various researchers have suggested that longer glances may be associated with poorer driving performance. For example, Wierwille (1993) suggests a 1.6 s criterion as representing a long glance away from the forward roadway. As shown in Figure 23, the distributions of glance duration were similar across all event types, and there was no obvious pattern of longer glances being associated with any of the event types.

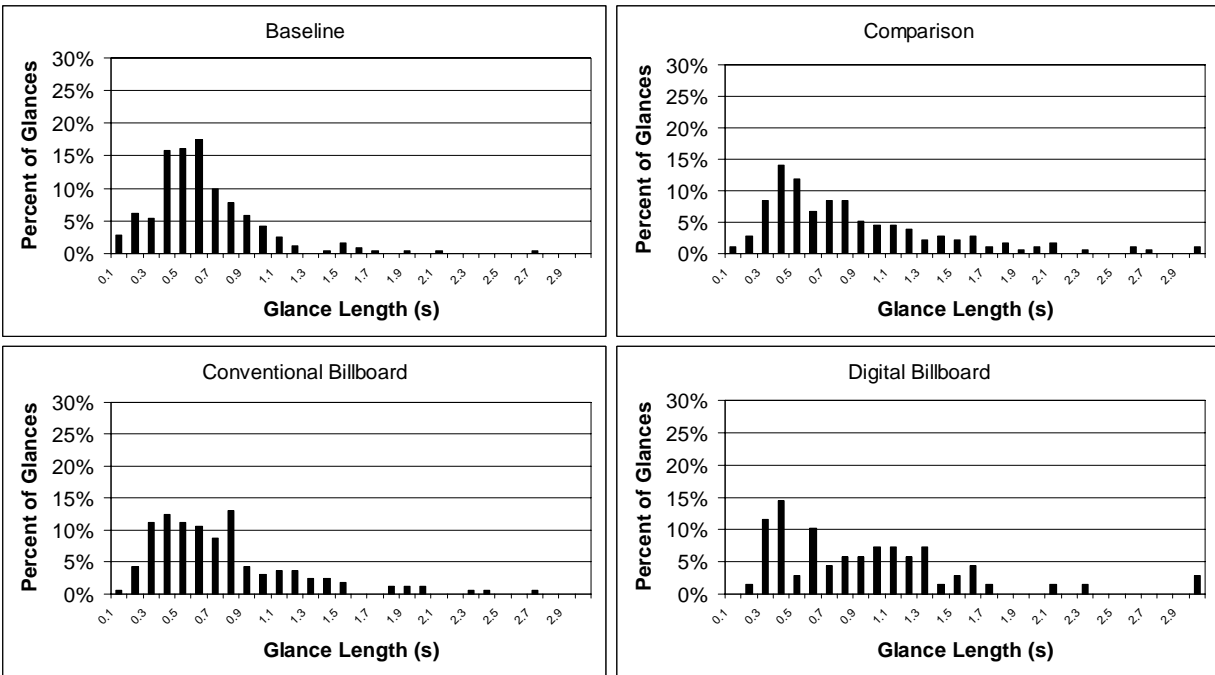

Figure 23. Tails analysis for the distribution of glance duration, (method described in Horrey and Wickens, 2007).

Discussion of Daytime Eyeglance Results. Results showed that digital billboards were not associated with changes in overall glance patterns (overall number of glances or percent eyes-on-road time). Likewise, digital billboards were not associated with more frequent glances towards the direction where the billboard was located. However, digital billboards in both the left and right directions were associated with longer glances in that direction.

There were only five digital billboards along the route (these were all that were available). This led to low statistical power for the digital comparisons, especially when the digital billboards were separated into left and right (two in one direction and three in the other). To increase power and verify the above findings, the data were next aggregated so that all glances in the direction where an event was located were included. For glance frequency, there were still no significant differences in the number of glances depending on event type ($F_{3, 91} = 1.22, p = 0.3065$). For glance duration, the findings from above were also confirmed with this combined analysis ($F_{3, 91} = 4.98, p = 0.0030$). Digital billboards and comparison sites did not differ from one another, but each differed from conventional billboards and baseline events. Conventional billboards and baseline events did not differ from one another; these results are shown in Figure 24.

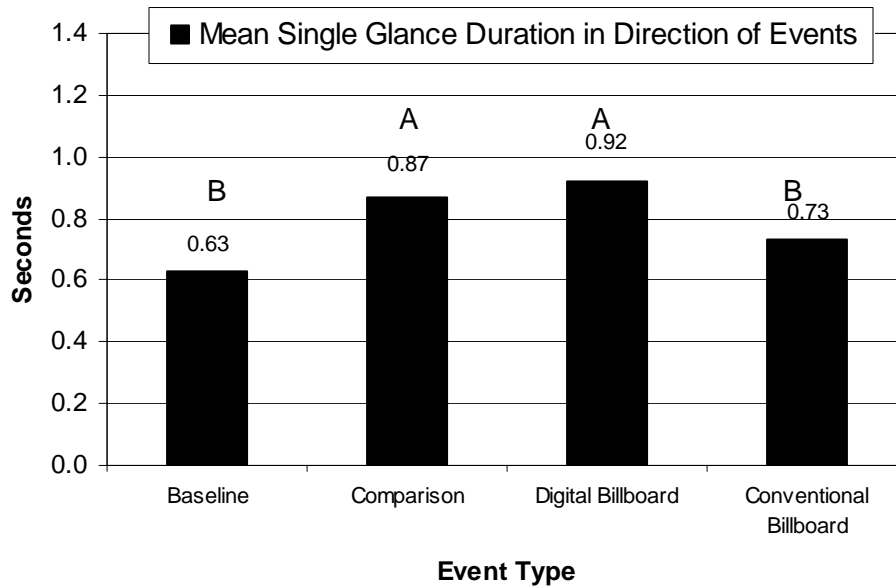

Figure 24. Mean Single Glance Time for Glances in the Direction of Events. (Data points with a shared letter do not differ significantly from one another.)

It should also be noted that digital billboards did not differ in glance duration from comparison events for left side, right side, or the combined comparison. Several of the comparison events had a digital component, but in the form of on-premises signing rather than as billboards. One comparison event used full motion video at times. Thus, it is not surprising that these event types revealed similar glance duration patterns. Finally, it should be noted that the results for conventional billboards were similar to those found in the Charlotte study, with very few differences between conventional billboards and either comparison events or baseline events.

Speed maintenance. As shown in Figure 25, there were differences in the standard deviation of speed for the different event types. These differences were statistically significant ($F_{3, 96} = 5.33$, $p = 0.0019$), with conventional billboards showing a higher speed deviation than baseline and digital billboards, but not different from comparison sites. Baseline events, comparison events, and digital billboards did not differ from one another. Much of this difference may be because there is typically greater speed deviation on surface streets than on interstates, and all of the digital billboards were on interstates. To account for this in the research design, the same analysis was conducted, but using only events occurring on interstates. In this analysis, there were no significant differences in standard deviation of speed ($F_{3, 96} = 1.66$, $p = 0.1819$), as shown in Figure 26.

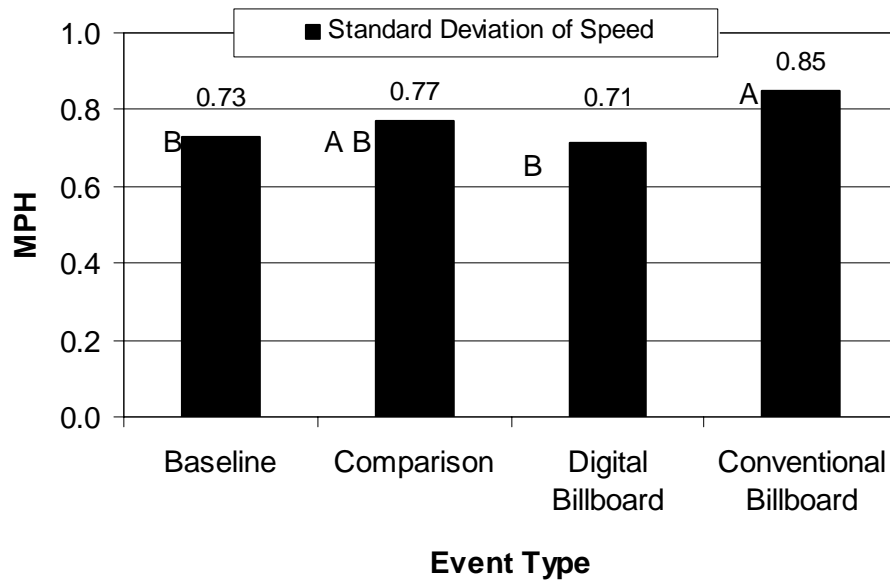

Figure 25. Standard Deviation of Speed by Event, in miles per hour. (Data points with a shared letter do not differ significantly from one another.)

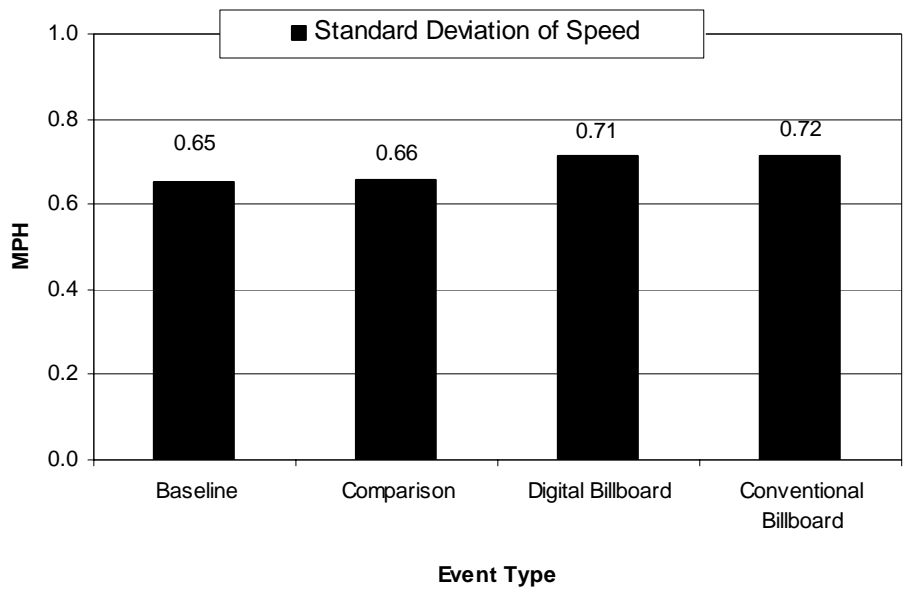

Figure 26. Standard Deviation of Speed by Event for Events Occurring on Interstates, in miles per hour. (None of the observed differences was significant.)

Lane keeping. The standard deviation of lane position was calculated for each event. Standard deviation was used instead of average lane position, because average lane position can be to the right or left, and thus an average would tend to wash out true differences, while standard deviation takes overall deviation into account, regardless of left or right. While there appeared to be differences in lane keeping for the different event types as shown in Figure 27, these differences did not quite reach significance ($F_{3,91} = 2.46, p = 0.0673$). Nevertheless, the trend is that digital billboards and conventional billboards seem to be related to poorer lane keeping, and it is likely that a larger sample would have shown significance for this measure.

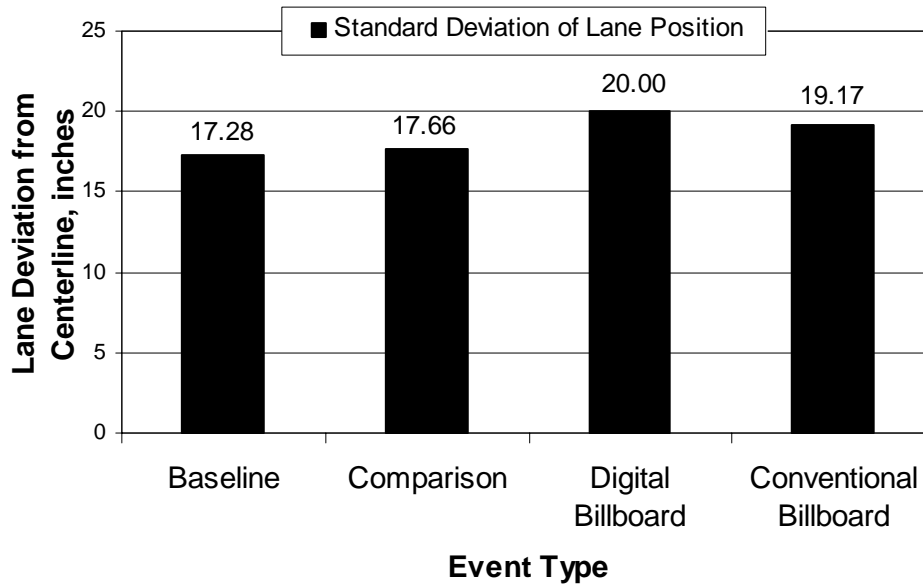

Figure 27. Standard Deviation of Lane Position by Event, in inches. (None of the observed differences was significant.)

Other findings

Road Type. There were significant differences in the two overall eyeglance measures, both of which indicated a more active glance pattern on surface streets. The eyes-on-road percentage was higher for interstate events than for surface street events (71% for interstate vs. 64% for surface streets; $F_{1,32} = 30.29, p < 0.0001$). There were also more total glances during an event on surface streets as opposed to on the interstates (6.3 glances for interstate vs. 7.2 glances for surface streets; $F_{1,32} = 10.51, p < 0.0028$). There were no significant differences for the eyeglance measures associated with the left or right side of the road. These findings are consistent with the findings of the Charlotte study, in that eyeglance patterns tend to be more active while driving on surface streets due to driver monitoring of driveways, intersections, and on-coming traffic.

Familiarity. Drivers spent significantly more time with their eyes on the road while driving on unfamiliar roads (73% for familiar roads and 75% for unfamiliar roads; $F_{1,22} = 4.81, p = 0.0392$). However, this small significant difference likely has no practical implications, especially given that the overall glance frequency was not significant ($F_{1,22} = 1.38, p = 0.2530$).

There were no significant differences for speed maintenance or lane keeping depending on familiarity with the route segment. These results are likely confounded by the fact that most of the road segments that drivers classified as familiar were the interstate portions of the route, while the unfamiliar roads tended to be the surface street sections.

Age. There were two age findings in the eyeglance measures. Older drivers had higher eyes-on-road percentage than did younger drivers (73% for older and 67% for younger; $F_{1,32} = 4.46$, $p = 0.0426$). Younger drivers also had more frequent right forward glances for events to the right than did older drivers (younger = 1.55 right forward glances per event; older = 1.34 right forward glances per event; $F_{1,32} = 4.42$, $p = 0.0436$). Younger drivers thus seemed to have a slightly more active glance pattern than older drivers, but this did not show up in very many of the eyeglance measures examined. There were no age differences for speed keeping or lane maintenance.

Gender. There were no significant findings for gender for eyeglance, speed maintenance, or lane keeping measures.

Driving Performance Results – Nighttime

Event Type

Eyeglance results. As mentioned previously, there were about one-third fewer data points for the nighttime portion of the study, which was considered an exploratory study. Thus, the results in this section are presented descriptively, without statistical analysis. Where the differences shown are strong, it is likely that a larger study would show statistical significance, while weak differences may or may not hold up with a larger study. Four eyeglance measures were examined for the nighttime data: eyes-on-road percent, overall glance frequency, mean glance duration in the direction of an event, and mean number of glances in the direction of an event. Eyes-on-road percent is presented in Figure 28, which shows that digital billboards and comparison events tended to have less eyes-on-road time at nighttime than either baseline events or conventional billboards. The overall glance frequency was also higher in the presence of digital billboards and comparison events at nighttime, as shown in Figure 29. These two findings taken together show a more active glance pattern at nighttime in the presence of these two event types, which mirrors some of the daytime findings.

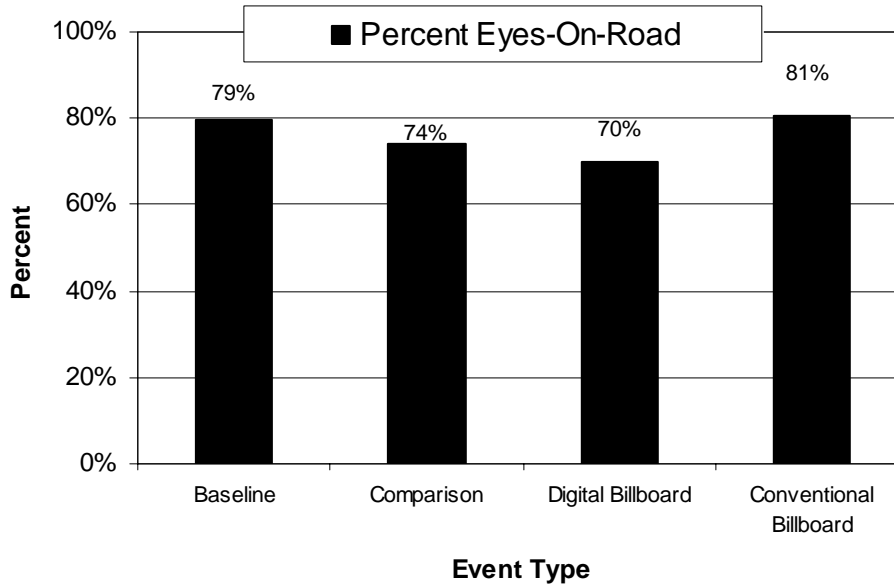

Figure 28. Eyes-on-Road Percent by Event Type for the Nighttime Exploratory Study.

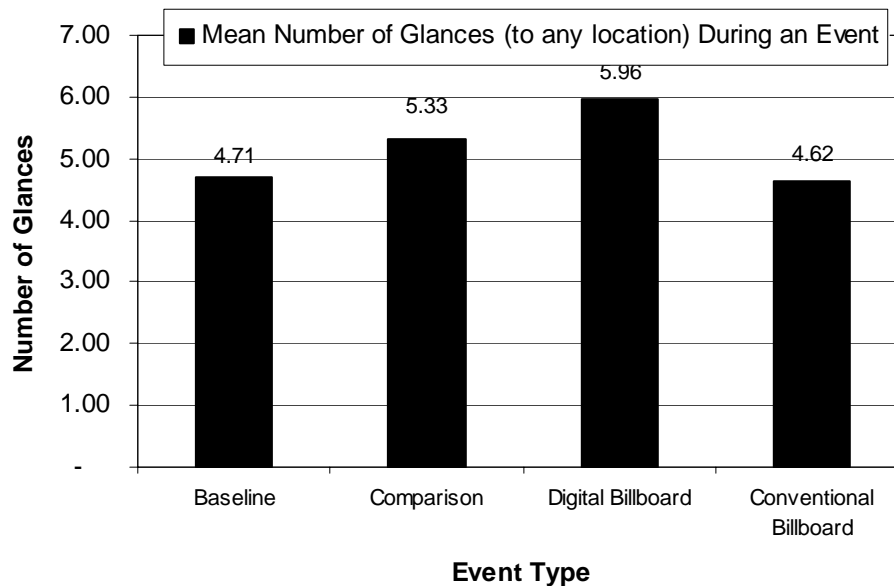

Figure 29. Overall Glance Frequency by Event Type for the Nighttime Exploratory Study.

The mean glance duration for glances in the direction of an event also showed higher values for digital billboards and comparison events; however, in this case, the comparison sites appeared to have longer glance times than did the digital billboards (Figure 30). The mean number of glances in the direction of an event again showed digital billboards and comparison events as having higher values than either baseline events or conventional billboards, as shown in Figure 31. Taken together, these four findings indicate that digital billboards and comparison events

may result in more active glance patterns overall, as well as more frequent and longer glances towards the digital billboards and comparison events.

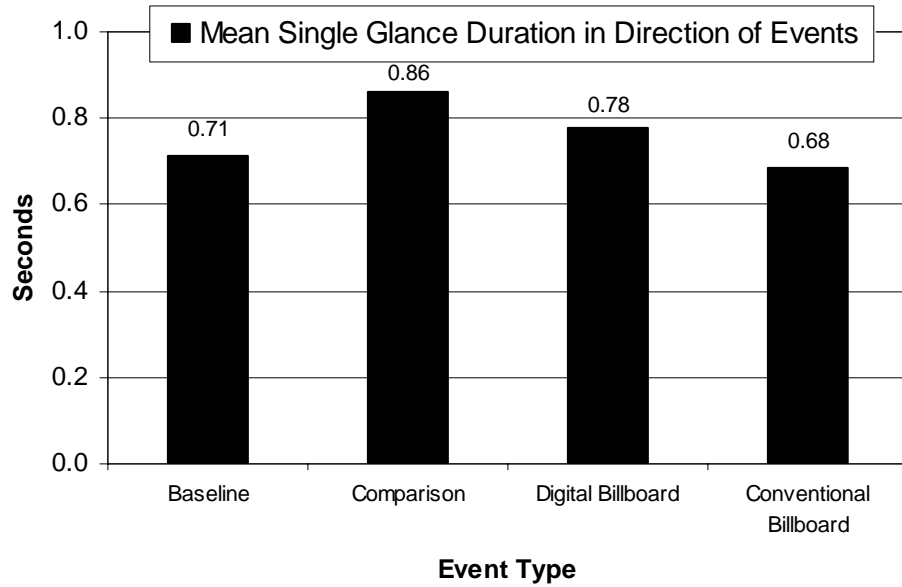

Figure 30. Mean Glance Time for Glances in the Direction of an Event for the Nighttime Exploratory Study.

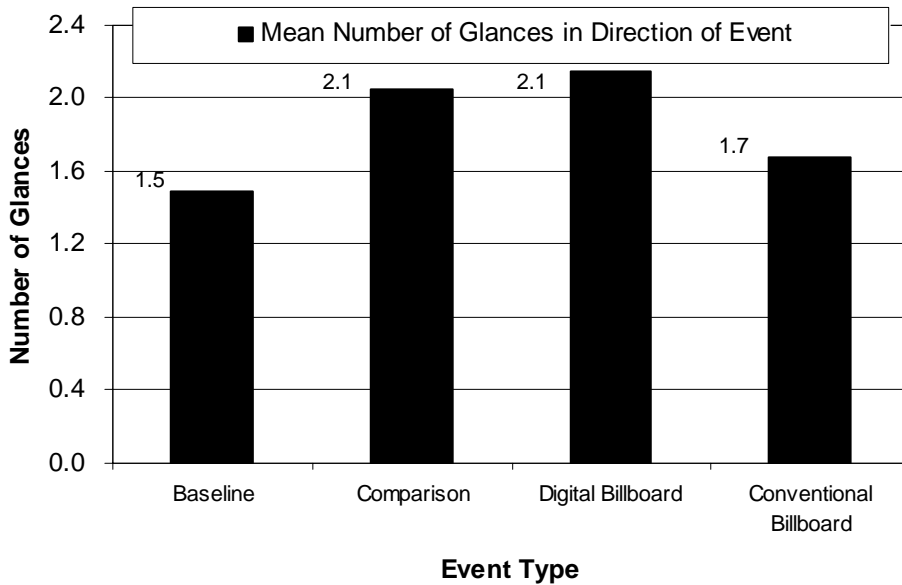

Figure 31. Mean Number of Glances in the Direction of an Event for the Nighttime Exploratory Study.

Speed maintenance. Figure 32 shows that the standard deviation of speed appeared to be higher in the presence of both conventional and digital billboards than for baseline and comparison events. If this effect is related to the event type, it may be due to the attempt to read the copy of these signs at night while driving. If this is true, the higher value shown for conventional billboards may indicate that these signs are more difficult to read at night than are the digital billboards.

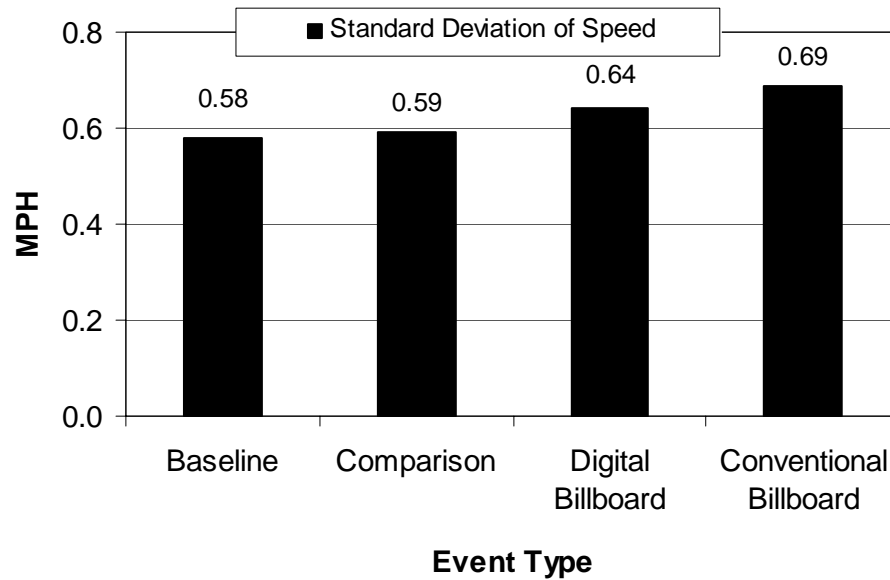

Figure 32. Speed Maintenance as Measured by the Standard Deviation of Speed by Event for the Nighttime Exploratory Study.

Lane keeping. Lane keeping also showed a trend towards greater lane deviations in the presence of both digital billboards and conventional billboards as shown in Figure 33. As was true for speed maintenance, conventional billboards showed higher values than did digital billboards. Again, this may be an indication of the difficulty of reading these signs at night.

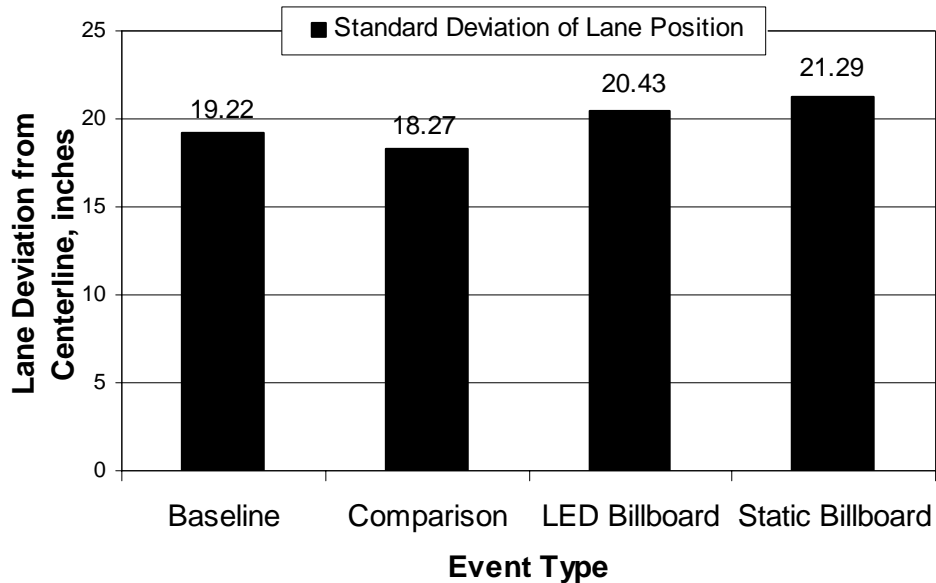

Figure 33. Lane Keeping as Measured by the Standard Deviation of Lane Position by Event for the Nighttime Exploratory Study.

Nighttime Luminance Measures

The luminance was measured with a Radiant Imaging Charge-Coupled Device (CCD) photometer with a 300 mm lens. The CCD photometer provided a method of capturing the luminance of an entire scene at one time. Luminance represents the amount of light that is projected off a surface in a given direction. For this investigation, the direction of interest was towards the driver. Luminance is measured in candelas per meter squared.

The photometer was located in the experimental vehicle as close to the driver's position as possible (Figures 34 and 35). The experimental vehicle was then driven to the sign location and stopped on the side of the road. Images of the sign were then acquired. For multiple face signs such as the digital and the tri-visions signs, each of the presented messages was imaged. Using the software provided with the system, the average luminance of the sign and each message was measured. The photometer was connected to a laptop computer in the back seat that stored the data as the images were acquired. All measurements were taken at night. Figure 36 shows the average luminance measures for each of the four event types measured in candelas per meter squared. Note that the digital billboards had noticeably higher luminance values than any of the other event types, even though their luminance was automatically reduced at night. This probably explains some of the driver performance findings in the presence of the digital billboards. The overall ranking of luminance by event (digital billboards were the highest, followed in order by comparison events, conventional billboards, and baseline events) closely mirrors the rankings of many of the performance measures for both daytime and nighttime, including eyeglance, speed maintenance, and lane keeping. Altogether, there were 74 measurements (17 for comparison events, 36 for digital billboards, 6 for conventional billboards, and 15 for baseline events). More readings were taken for the digital billboards because each message was measured individually.



Figure 34. Bracket for Radiant Imaging CCD Photometer.



Figure 35. Radiant Imaging CCD Photometer in Position for Measurements, with Experimenter Making Final Adjustments.

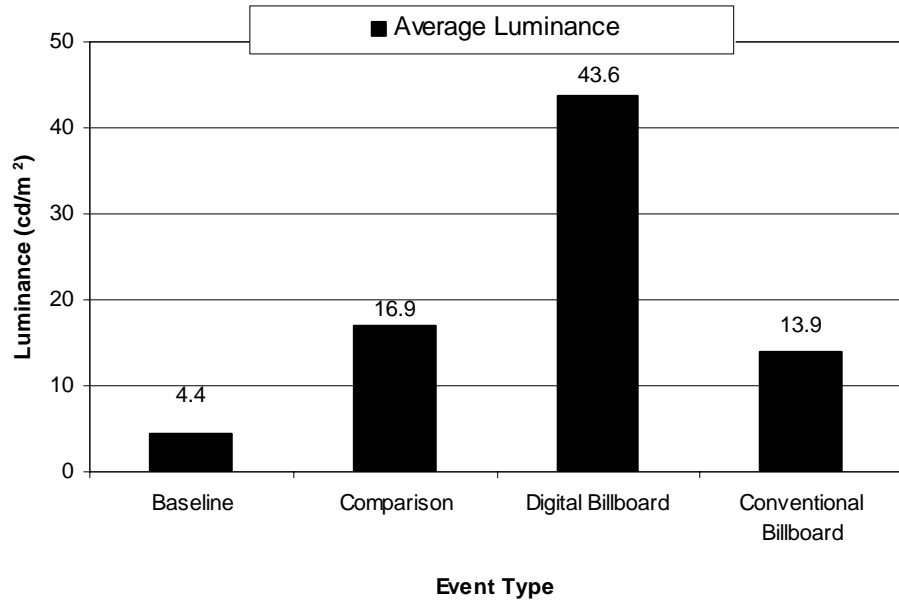

Figure 36. Average Luminance of the Four Event Types, in Candelas per Meter Squared.

COMPARISONS TO THE CHARLOTTE STUDY

There were several similarities and several differences between this study and the study conducted in Charlotte, NC. The original intent was to make the studies as similar as possible, and this was achieved to the degree possible, as demonstrated by the following items:

- Both were conducted in mid-sized cities (Charlotte population: 540,828; Cleveland population: 478,403; both figures taken from US Census 2000).
- Both were conducted in areas with similar terrain (fairly flat, with a few rolling hills; Charlotte elevation: 650 feet; Cleveland elevation: 581 feet).
- Both studies included conventional billboards, comparison events, and baseline events.
- Both studies showed similar results when conventional billboards were compared to baseline and comparison sites (very few differences in eyeglance measures, speed maintenance, or lane keeping for conventional billboards as compared to baseline events and comparison events).
- Both studies used 36 participants who performed the experiment in the daytime, equally divided into four age by gender cells (nine older males, nine older females, nine younger males, and nine younger females).
- Both included participants who lived and worked in the area and were familiar with at least some parts of the route.
- Both studies were conducted during similar times of day (between rush hours, from about 9 a.m. to 4 p.m.).
- Both studies included surface streets and interstates.
- Both studies used the same make and model of vehicle, and similar instrumentation.
- Both studies used the same basic protocols and questionnaires.
- The data were reduced and analyzed in a similar fashion using the same software tools.
- Both studies were sponsored by a foundation with strong ties to the outdoor advertising industry. Thus, in each study every effort was made to remove sources of potential bias. These efforts included:
 - Final selection of route and events were made by VTTI project staff;
 - Data collection and reduction was as automated as possible (speed and lane keeping data were totally automated, and involved no human intervention or interpretation); and
 - In the case of eyeglance data reduction, where human intervention and interpretation were necessary, data reductionists knew very little about the project, its focus, or its sponsor. They evaluated each event according to a number code, with no knowledge about whether the number represented a digital billboard, conventional billboard, comparison event, or baseline event.
 - In addition, the participants themselves did not know the true purpose of the study.

Differences between the two studies included the following items; these were motivated primarily by the difference in focus between the two studies:

- The focus of the Charlotte study was driver performance in relation to conventional billboards, while the focus of the Cleveland study was driver performance in relation to digital billboards.
- The comparison events in each study were chosen to be comparable to the events of interest. In the Charlotte study, the comparison events were chosen prior to data collection and were considered by the experimenters to be visually similar to conventional billboards. In the Cleveland study, the comparison events were again chosen prior to data collection and were considered by the experimenters to be visually similar to digital billboards.
- The Cleveland route was longer (50 miles, versus 35 miles for the Charlotte study; this was due to the need to include as many digital billboards as possible).
- The Cleveland subject pool was not as representative of the demographics of Cleveland as was the Charlotte subject pool (in terms of race and ethnicity). For example, Cleveland is approximately 41% Caucasian, while 97% of the participants were Caucasian. Charlotte is 58% Caucasian and 61% of the participants in that study were Caucasian.
- The Charlotte study examined the 7 seconds preceding each event, while the Cleveland study used 8 seconds (to increase the chances of capturing data for a message change for the digital billboards).
- The Cleveland study included digital billboards, which were not present in the Charlotte study.
- The Cleveland study included an exploratory nighttime study using 12 of the daytime participants.
- Luminance measures were obtained for the Cleveland study as part of the nighttime exploratory study.
- The Charlotte study included some US highway type roads that were not available in the Cleveland study.
- Because the digital billboards were all located on the interstate segments of the route, the road type and event type were confounded, unlike in the Charlotte study. To get around this, some of the analyses examined only events occurring on interstates.
- Because most of the drivers were more familiar with the interstate segments than with the surface streets, road type and familiarity were also confounded to a greater degree than in the Charlotte study. However, this interaction was not a primary focus of the current study.
- The Cleveland study was conducted in late fall and early winter, while the Charlotte study was conducted in late spring.

CONCLUSIONS

As with all studies, especially those conducted in real-world environments, the research design demonstrated both limitations and strengths. The study was designed to be as similar as possible to the study previously conducted in Charlotte, NC, with the major exception of the focus of the study (conventional billboards for Charlotte and digital billboards for Cleveland). The studies were similar in many important aspects with the exception of the location of the digital billboards. In the Charlotte study, billboards were present on all road types, while in Cleveland, all of the digital billboards were located along interstate highways. Thus, no conclusions can be made regarding the potential impact of digital billboards located on surface streets on driver behavior or performance. Despite this one flaw, necessitated by the real-world constraints of the digital billboard locations, the overall findings of this study were consistent and compelling.

The overall conclusion, supported by both the eyeglance results and the questionnaire results, is that the digital billboards seem to attract more attention than the conventional billboards and baseline sites (as shown by a greater number of spontaneous comments regarding the digital billboards and by longer glances in the direction of the billboards). The comparison events, 25% of which included signs with digital components, showed very similar results to the digital billboards. Thus, there appears to be some aspect of the digital billboards and on-premises signs that holds the driver's attention once the driver has glanced in that direction. This is most likely the result of the intrinsic lighting of these signs, which is noticeable even during the daytime. Drivers may also have maintained longer glances towards the digital billboards in the hopes of catching the next message (knowing that the message changed periodically), although an analysis of longer glances did not bear this out.

Although exploratory in nature, the nighttime results were very similar to the daytime results, with degraded eyeglance performance for digital billboards and comparison events. The digital billboards were also found to have much higher luminance at nighttime than any of the other event types.

These particular LED billboards were considered safety-neutral in their design and operation from a human factors perspective: they changed only once every eight seconds, they changed instantaneously with no special effects or video, they looked very much like conventional billboards, and their luminance was attenuated at night. It is thus quite likely that digital signs with video, movement, higher luminance, shorter on-message duration, longer transition times, and special effects would also be related to differences in driver behavior and performance. Because of the lack of crash causation data, no conclusions can be drawn regarding the ultimate safety of digital billboards. Although there are measurable changes in driver performance in the presence of digital billboards, in many cases these differences are on a par with those associated with everyday driving, such as the on-premises signs located at businesses. Conventional billboards were shown both in the current study and in the Charlotte study to be very similar to baseline and comparison events in terms of driver behavior and performance; thus, the design of digital billboards should be kept as similar as possible to conventional billboards.

REFERENCES

- Alm, H. & Nilsson, L. (1994). Changes in driver behaviour as a function of handsfree mobile phones—a simulator study. *Accident Analysis and Prevention*, 26 (4), 441-451.
- Andreassen, D.C. (1985). Technical Note No. 1: Traffic accidents and advertising signs. *Australian Road Research Board*, 15(2), 103-105.
- Beijer, D. D., Smiley, A., & Eizenman, M. (2004). Observed driver glance behavior at roadside advertising. *Transportation Research Record*, No. 1899, 96-103.
- Brown, I. D., Tickner, A. H., & Simmonds, D. C. V. (1969). Interference between concurrent tasks of driving and telephoning. *Journal of Applied Psychology*, 53 (5), 419-424.
- Crundall, D., Van Loon, E., & Underwood, G. (2006). Attraction and distraction of attention with roadside advertisements. *Accident Analysis and Prevention*, 38 (4), 671–677.
- Dingus, T. A., Klauer, S. G., Neale, V. L., Petersen, A., Lee, S. E., Sudweeks, J., Perez, M. A., Hankey, J., Ramsey, D., Gupta, S., Bucher, C., Doerzaph, Z. R., Jermeland, J., and Knipling, R.R. (2006). *The 100-Car Naturalistic Driving Study: Phase II – Results of the 100-Car Field Experiment*. (Report No. DOT HS 810 593). Washington, D.C.: National Highway Traffic Safety Administration.
- Farber, E., Blanco, M., Foley, J., Curry, R., Greenberg, J. A., & Serafin, C. P. (2000). *Surrogate measures of visual demand while driving*. Dearborn, MI: Ford Motor Company-Scientific Research Laboratory.
- Farbry, J., Wochinger, K., Shafer, T., Owens, N, and Nedzesky, A. (2001). Research review of potential safety effects of electronic billboards on driver attention and distraction (Final Report). Federal Highway Administration, Washington, DC.
- Garvey, P. M., Thompson-Kuhn, B. and Pietrucha, M. T. (1995). Sign visibility literature review. United States Sign Council (USSC) Research Project, Final Report.
- Gellatly, A. W., & Kleiss, J. A. (2000). Visual attention demand evaluation of conventional and multifunction in-vehicle information systems. In *Proceedings of the IEA 2000/HFES 2000 Congress*, 3, 282-285. Santa Monica, CA: Human Factors and Ergonomics Society.
- GES. (2002). *National Automotive Sampling System (NASS) General Estimates System (GES) Analytical User's Manual 1988-2002*. Washington, DC: U.S. Department of Transportation, National Highway Traffic Safety Administration.
- Glaze, A. L., and Ellis, J. M. (2003). Pilot study of distracted drivers. *Transportation Safety Training Center for Public Policy*. Richmond, VA: Virginia Commonwealth University.
- Hanowski R .J., Wierwille W. W., and Dingus T. A. (2003). An on-road study to investigate fatigue in local/short haul trucking. *Accident Analysis and Prevention*, 35(2), 153-160.
- Horrey, W. J., and Wickens, C. D. (2007). In-vehicle glance duration: Distributions, tails and a model of crash risk. *Proceedings of the 2007 Transportation Research Board Meeting*. Washington, DC: TRB.

- Lee, S. E., Olsen, E. C. B., and DeHart, M. C. (2004). Driving performance in the Presence and absence of billboards. Report commissioned by the Foundation for Outdoor Advertising Research and Education.
- Kurokawa, K., & Wierwille, W. W. (1990). Validation of a driving simulation facility for instrument panel task performance. *Proceedings of the Human Factors Society 34th Annual Meeting*, 1299-1303.
- McMonagle, J. C. (1951). Accident analysis – Telegraph Road 1947-1948. *Highway Research Board Bulletin*, 30, 29-41.
- Mourant, R. R., & Rockwell, T. H. (1970). Mapping eye-movement patterns to the visual scene in driving: An exploratory study. *Human Factors*, 12(1), 81-87. Santa Monica, CA: Human Factors Society.
- Mourant, R. R., & Rockwell, T. H. (1972). Strategies of visual search by novice and experienced drivers. *Human Factors*, 14(4), 325-335. Santa Monica, CA: Human Factors Society.
- Mourant, R. R., Rockwell, T. H., & Rackoff, N. J. (1969). Drivers' eye movements and visual workload. *Highway Research Record*, 292, 1-10. Washington, D. C.: National Research Council.
- Nagata, M., & Kuriyama, H. (1985). *Drivers' visual behavior with door and fender mirror systems* (SAE Paper No. 850330). Warrendale, PA: Society of Automotive Engineers.
- Parkes, A. M, Ward, N. J., & Vaughan, G. (2001). A human factors evaluation of a novel display and control concept for in-vehicle audio systems: a case study. *International Journal of Vehicle Design*, 25 (4), p. 339-352.
- Rockwell, T. H. (1988). *Spare Visual Capacity in Driving-Revisited (New Empirical Results for an Old Idea)*. In *Proceeding of Vision in Vehicles II* (pp. 31 7-324). A G Gale et al. (Editors). Elsevier Science Publishers B. V. (North-Holland).
- Rusch, W. A. (1951). Highway accident rates as related to roadside business and advertising. *Highway Research Board Bulletin*, 30, 46-50.
- Rykken, K. B. (1951). Minnesota roadside survey: progress report on accident, access point and advertising sign study in Minnesota. *Highway Research Board Bulletin*, 30, 42-43.
- Salvucci, D. D. (2002). Modeling driver distraction from cognitive tasks. In *Proceedings of the 24th Annual Conference of the Cognitive Science Society* (pp. 792-797). Mahwah, NJ: Lawrence Erlbaum Associates. Accessed 9 October 2003 from <http://hmil.cs.drexel.edu/papers/CSC02.pdf>.
- Serafin, C., Wen, C., Paelke, P., & Green, P. (1993). Car phone usability: A human factors laboratory test. *Proceedings of the Human Factors and Ergonomics Society Annual Meeting*, (pp. 220-224). Santa Monica, CA: Human Factors and Ergonomics Society.
- Tantala, M. W. & Tantala, P. J. (2005). An examination of the relationship between advertising signs and traffic safety. In *Proceedings of the 2005 Transportation Research Board Meeting*. Washington, DC: TRB.
- Taoka, G., T. (1990). Duration of drivers' glances at mirrors and displays. *Institute of Transportation Engineers Journal*, October, 60(10), 35-39.

- Tessmer, J. M. (2002). *Fatal Accident Reporting System Analytic Reference Guide, 1975-2002*. Washington, DC: U.S. Department of Transportation, National Highway Traffic Safety Administration.
- Tijerina, L., Kiger, S. M., Rockwell, T. H., & Tornow, C. (1995). Workload assessment of in-cab text message system and cellular phone use by heavy vehicle drivers on the road. In *Proceedings of the Human Factors and Ergonomics Society 39th Annual Meeting* (pp. 1117-1121). Santa Monica, CA: Human Factors and Ergonomics Society.
- Tijerina, L., Palmer, E. B., & Goodman, M. J. (1999). Individual differences and in-vehicle distraction while driving: a test track study and psychometric evaluation. In *Proceedings of the Human Factors and Ergonomics Society 43rd Annual Meeting*. pp. 982-986. Santa Monica, CA: Human Factors and Ergonomics Society.
- Wachtel, J. and Netherton, R. (1980). *Safety and environmental design considerations in the use of commercial electronic variable-message signage* (Final Report). Federal Highway Administration, Washington, DC.
- Waugh, J. D., Glumm, M. M., Kilduff, P. W., Tauson, R. A., Smyth, C. C., & Pillalamarri, R. S. (2000). Cognitive workload while driving and talking on a cellular phone or to a passenger. In *Proceedings of the IEA 2000/HFES 2000 Congress*. 6, 276-279. Santa Monica, CA: Human Factors and Ergonomics Society.
- Wierwille, W. W. (1993). Visual and manual demands of in-car controls and displays. In B. Peacock and W. Karwowski (Eds.), *Automotive Ergonomics* (pp. 299-320). Washington, D.C.: Taylor & Francis.
- Wierwille, W. W., Antin, J. F., Dingus, T. A., & Hulse, M. C. (1988). Visual attentional demand of an in-car navigation display system. In A. G. Gale, M. H. Freeman, C. M. Haslegrave, P. Smith, & S. P. Taylor (Eds.), *Vision in Vehicles II* (pp. 307-316). Amsterdam: North Holland Press.
- Zwahlen, H. T., Adams, C.C., & DeBald, D. P. (1988). Safety Aspects of CRT touch panel controls in automobiles. In A.G. Gale, Freeman, M. H., Haslegrave, C. M. Smith, P., & Taylor, S. P. (eds.). *Vision in Vehicles II* (335-344). Amsterdam: Elsevier.

APPENDICES

Appendix A: Initial Participant Telephone Screening Form

FOARE Cleveland Participant Screening Script

Note to Researcher:

Initial contact between participants and researchers may take place over the phone. If this is the case, read the following Introductory Statement, followed by the questionnaire. Regardless of how contact is made, this questionnaire must be administered verbally before a decision is made regarding suitability for this study.

Introductory Statement:

After prospective participant calls or you call him/her, use the following script as a guideline in the screening interview.

Hello. My name is Melinda McElheny and I'm a researcher with the Virginia Tech Transportation Institute in Blacksburg, Virginia. The project involves participation in a driving study to help researchers understand how people drive.

This study involves coming to a meeting room at the Residence Inn by Marriott in Independence, OH, just south of Cleveland on I-77 one time for approximately 2 hours. During this session you would help us by driving one of our vehicles along a pre-selected route for about 50 miles. The vehicle will be equipped with data collection equipment. Does this sound interesting to you?

Next, I would like to ask you several questions to see if you are eligible to participate.

Questions

1. Do you have a valid driver's license?

Yes _____ No _____

2. How often do you drive each week?

Every day _____ At least 2 times a week _____ Less than 2 times a week _____

3. How old are you? _____ (stop if not 18-35 years old or 50-75 years old.)

4. What type of vehicle do you usually drive? _____

5. Have you previously participated in any experiments at the Virginia Tech Transportation Institute? If so, can you briefly describe the study?

Yes _____
No _____

6. How long have you held your drivers' license? _____

7. Are you able to drive an automatic transmission without assistive devices or special equipment? Yes _____ No _____

8. Do you have a history of any of the following? If yes, please explain.

Stroke	No _____	Yes _____
Brain tumor	No _____	Yes _____
Head injury	No _____	Yes _____
Epileptic seizures	No _____	Yes _____
Respiratory disorders	No _____	Yes _____
Motion sickness	No _____	Yes _____
Inner ear problems	No _____	Yes _____
Dizziness, vertigo, or other balance problems	No _____	Yes _____
Diabetes	No _____	Yes _____
Migraine, tension headaches	No _____	Yes _____

9. (Females only, of course) Are you currently pregnant?

Yes _____ No _____ (If “yes” then read the following statement to the participant: *“It is not recommended that pregnant women participate in this study. However, female participants who are pregnant and wish to participate must first consult with their personal physician for advice and guidance regarding participation in a study where risks, although minimal, include the possibility of collision and airbag deployment.”*)

10. Are you currently taking any medications on a regular basis? If yes, please list them.

Yes _____
No _____

11. Do you have normal or corrected to normal hearing and vision? If no, please explain.

Yes _____
No _____

12. Have you ever had radial keratotomy, LASIK, or other eye surgeries? If yes, please specify.

Yes _____
No _____

I would like to take your name, phone number or phone numbers, and/or email where you can be reached and hours/days when it's best to reach you.

Name _____ Male/Female

Phone Numbers _____ Age: _____

Best Time to Call _____

Email _____

When contacting participants for scheduling purposes, the following statement must be included in the conversation. *“We ask that all participants refrain from drinking alcohol and taking any substances that will impair their ability to drive prior to participating in our study.”*

Criteria for Participation:

- 1. Must hold a valid driver's license.**
- 2. Must be 18-35 or 50-75 years of age.**
- 3. Must drive at least 2 times a week.**
- 4. Must have normal (or corrected to normal) hearing and vision.**
- 5. Must be able to drive an automatic transmission without special equipment.**
- 6. Cannot have lingering effects of brain damage from stroke, tumor, head injury, recent concussion, or infection. Cannot have had epileptic seizures within 12 months, respiratory disorders, motion sickness, inner ear problems, dizziness, vertigo, balance problems, diabetes for which insulin is required, chronic migraine or tension headaches.**
- 7. Cannot currently be taking any substances that may interfere with driving ability (cause drowsiness or impair motor abilities).**
- 8. No history of radial keratotomy, LASIK eye surgery, or any other ophthalmic surgery.**
- 9. Must be willing to drive without sunglasses or tinted lenses.**
- 10. Must live or work in the Cleveland area.**

A total of 2 hours of time will be needed. What days and times would you be able to participate?

Saturday	Sunday	Monday	Tuesday	Wednesday	Thursday	Friday
9:30	9:30	9:30	9:30	9:30	9:30	9:30
11:45	11:45	11:45	11:45	11:45	11:45	11:45
2:00	2:00	2:00	2:00	2:00	2:00	2:00

Thank you for your time. I will contact you to schedule a session if you are selected as a participant.

Appendix B: Informed Consent Form**VIRGINIA POLYTECHNIC INSTITUTE AND STATE UNIVERSITY****Informed Consent for Participants
of Investigative Projects**

Title of Project: Influence of driver characteristics on driving performance

Investigators: Dr. Suzanne E. Lee, Research Scientist, Virginia Tech Transportation Institute.

Dr. Ronald B. Gibbons, Research Scientist, Virginia Tech Transportation Institute.

Melinda J. McElheny, Senior Research Specialist, Virginia Tech Transportation Institute.

I. The Purpose of this Research Project

This study will collect driver performance data to help understand the way people drive in a natural environment (with no experimenter present). The goal of this study is improve the understanding of how people drive.

II. Procedures

For this study you will be asked to drive on a loop-route on freeways and highways in Cleveland, Ohio. We want you to drive as you normally would on any roadway, following the typical laws and regulations of the road. The session is expected to last about two hours, including this orientation. You will then be paid for your participation.

This vehicle contains sensors and data processing equipment that will capture aspects of your driving behavior. Small video cameras are also mounted in the vehicle. One of these cameras will be directed toward your face while you are driving. The equipment has been installed in such a way that you will hardly be able to notice its presence. It will not interfere with your driving, and there is nothing special that you will need to do in regard to the equipment.

This experiment will consist of five experimental stages:

1. Introductory stage

This stage consists of preliminaries. You will be asked to read the informed consent form. Once you have signed this form, we will also ask to see your driver's license, and an eye exam will be administered. Finally, we will have you complete a medical questionnaire. Once you have completed this stage we will go on to stage 2.

2. Familiarization with the test vehicle

While the instrumented vehicle is parked you will be shown how to operate the vehicle (for example, lights, mirror adjustments, windshield wipers, etc.) as this may be different from your

personal vehicle. You will then be asked to set each control to the best level for your comfort and driving performance. You will then take a short drive with the experimenter riding along in the passenger's seat to become familiar with the vehicle. This stage should take approximately 15 minutes.

3. Preparation for loop route

The experimenter will then review the loop-route with you. You will be given a map and written directions that the experimenter will review with you.

4. Driving the loop route

You will then drive the instrumented vehicle for approximately 1.5 hours over the pre-planned loop route of approximately 50 miles. You are expected to follow the posted speed limit and to wear your seatbelt. Also, please stay in the right-hand lane to the extent possible during the drive. The loop route is to be completed in one session if possible.

5. Debriefing and Payment

After completing the experiment, you will return here for a short debriefing session. You will then be paid for your participation. It is expected that the complete session will last approximately 2 hours, including orientation, loop-route, and debriefing.

III. Risks

The experiment is believed to be minimal risk. There are risks or discomforts to which you are exposed in volunteering for this research. The risks in this study are the same as the risks normally associated with driving on public roadways. The risks involved include the following:

- 1) The risks normally associated with driving on commonly encountered roadway segments at freeway speeds, and if you are participating in the nighttime driving study, the risks include those normally associated with driving on similar roadway segments at night.
- 2) Possible fatigue due to the length of the experiment. However, the route will be selected to minimize the amount of driving required. You will be instructed to exit the roadway to take a break if you feel the need to do so at any time during the experimental session.
- 3) Cameras will videotape you as you drive the vehicle; therefore, we will ask you not to wear sunglasses. However, you should feel free to put on your sunglasses if this request at any time impairs your ability to drive the vehicle safely.

The following precautions will be taken to ensure minimal risk to you:

- 1) The experimenter will monitor you during the orientation drive and help you become familiar with the experimental vehicle. However, as long as the you are driving the research vehicle, it remains your responsibility to drive in a safe, legal manner.
- 2) You will be required to wear the lap and shoulder belt restraint system while in the car. The vehicle is also equipped with a driver's side airbag supplemental restraint system.
- 3) If an accident does occur, you will be instructed to call appropriate emergency services via a cell phone in the glove compartment, and then to call the experimenter. If a visit to a medical facility is required, you would be required to undergo examination by medical personnel.

- 4) A cell phone (stored in the glove compartment) will be made available for you to call the experimenter for any reason. You will be instructed to call only while the vehicle is in a safe location, and while the vehicle is not in motion.
- 5) All data collection equipment will be mounted such that, to the greatest extent possible, it does not pose a hazard to you in any foreseeable case.
- 6) None of the data collection equipment or the display technology interferes with any part of your normal field of view present in the automobile.

IV. Benefits of this Research Project

The information collected from this project will provide new information on how people tend to drive in a natural setting. This information will be used to improve roadway and vehicle design, so that roadside and in-vehicle devices can be better designed to fit in with what people expect. While there are no direct benefits of participating in this study, you may find the experiment interesting. No guarantee of benefits has been made to encourage you to participate. However, to avoid biasing other potential participants, you are requested not to discuss this study with anyone for at least 8 months after participation.

V. Extent of Anonymity and Confidentiality

The results obtained from this study will be kept completely anonymous. Your name will not appear on data derived from your session. Only a number will differentiate your data from others who take part in the study. This number, and not your name, will also be used in subsequent data analyses and reports.

As indicated, video will be recorded while you are driving. The video includes an image of your face, so that we can determine where you are normally looking. The video will be treated with confidentiality and kept secure. It will be shared only with other qualified researchers, and not published except as noted in the following paragraph.

If at a later time we wish to use the video information for other than research purposes, say, for public education, or if we wish to publish (for research or for other purposes) your likeness or other information from the study that identifies you either directly or indirectly, we will only do so after we have contacted you again and obtained your explicit permission.

VI. Compensation

You will be paid \$20 per hour for the time you actually spend in the experiment. It is estimated that the entire session, including orientation, driving, and debriefing will be 2 hours. Payment will be made in cash immediately after you have finished your participation.

VII. Freedom to Withdraw

You are free to withdraw at any time without penalty. If you choose to withdraw from this study you will be compensated for your time up until that point.

VIII. Medical Treatment and Insurance

If you should become injured in an accident, the medical treatment available to you would be that provided to any driver or passenger by emergency medical services in the vicinity where the accident occurs. The vehicle you will be driving is insured for automobile liability and

collision/comprehensive through Virginia Tech and the Commonwealth of Virginia. There is medical coverage for you under this policy. The total policy amount per occurrence is \$2,000,000. This coverage would apply in case of an accident, except as noted below.

Under certain circumstances, you may be deemed to be driving in the course of your employment, and your employer's worker's compensation provisions may apply in lieu of the Virginia Tech and Commonwealth of Virginia insurance provisions, in case of an accident. The particular circumstances under which worker's compensation would apply are specified in Virginia law. If worker's compensation provisions do not apply in a particular situation, the Virginia Tech and Commonwealth of Virginia insurance provisions will provide coverage.

Briefly, worker's compensation would apply if your driving for this research can be considered as part of the duties you perform in your regular job. If it is not considered as part of your regular job, then the insurance policy would apply.

IX. Approval of Research

You should know that this research project has been approved, as required by the Institutional Review Board for Research Involving Human Participants at Virginia Polytechnic Institute and State University, and the Virginia Tech Transportation Institution.

X. Participant's Responsibilities

I voluntarily agree to participate in this study. I have the following responsibilities:

- 1) I should not participate in this study if I do not have a valid driver's license or if I am not in good health.
- 2) I should notify the experimenter if at any time I do not want to continue my participation.
- 3) I should operate the instrumented vehicle in a safe and responsible manner.
- 4) I should answer all questions truthfully.

XI. Participant's Permission

Check one of the following:

- I have **not** had an eye injury/eye surgery (including, but not limited to, LASIK, Radial Keratotomy, and cataract surgery.)
- I **have** had an eye injury/eye surgery and I've have been informed of the possible risks to participants who have had eye surgery. I choose to accept this possible risk to participate in this study.

I have read and understand the Informed Consent and conditions of this project. I have had all my questions answered. I hereby acknowledge the above and give my voluntary consent for participation in this project.

If I participate, I may withdraw at any time without penalty. I agree to abide by the rules of this project.

Signature

Date

Should I have any questions about this research project or its conduct, I may contact:

Dr. Suzanne E. Lee, Principal Investigator (540) 231-1511
Melinda J. McElheny, Senior Research Specialist (540) 231-1557
David Moore, Chair of the Virginia Tech Institutional Review Board (540) 231-4991

Participants must be given a complete copy (or duplicate original) of the signed Informed Consent.

4. List any prescription or non-prescription drugs you are currently taking or have taken in the last 24 hours.

5. List the approximate amount of alcohol (beer, wine, fortified wine, or liquor) you have consumed in the last 24 hours.

6. Are you taking any drugs of any kind other than those listed in 4 or 5 above?

Yes No

Signature

Date

Appendix D: Post Drive-Questionnaire

Thank you for participating in this driving study. We appreciate your responses to the following items. All information will remain confidential.

1. Please check either “Familiar” (driven at least once a week) or “Not Familiar” (driven less than one time a week) for the following roadway sections:

I-480 between I-77 and 150 th	_____ Familiar	_____ Not Familiar
W.130 th –Bellaire–W.117 th	_____ Familiar	_____ Not Familiar
I-90 between 9 th and 185 th	_____ Familiar	_____ Not Familiar
Carnegie St.	_____ Familiar	_____ Not Familiar
I-77 between I-90 and Rockside	_____ Familiar	_____ Not Familiar

2. For the following systems, please check what you liked or disliked:

Seating	_____ like	_____ neutral	_____ dislike
Air conditioning	_____ like	_____ neutral	_____ dislike
Engine power	_____ like	_____ neutral	_____ dislike
Visibility	_____ like	_____ neutral	_____ dislike
Steering	_____ like	_____ neutral	_____ dislike

3. Please check the top five items that most caught your attention during your drive:

Surrounding traffic
 Other drivers
 Construction areas
 Road/street signs
 Emergency vehicles
 Buildings
 Landmarks
 Walls
 Landscaping/scenery
 Gas Stations
 Restaurants
 Motels/Hotels
 Billboards
 Towers
 Highway/Exit Signs
 Smoke Stacks
 Apartments/housing
 Other _____

4. Did you experience any problems while following the written directions? ___Yes ___No
If yes, please describe:

5. What was most memorable about the drive? For example, where there any objects that stood out?

6. What other activities do you typically engage in while driving?

7. Does anything about other drivers bother you? If so, please briefly describe:

8. Please provide any other input about this study:

9. In what city do you live?

10. In what city do you work?

11. What level of education have you completed?

- ___Elementary/Secondary
 - ___Junior High School
 - ___High School degree
 - ___2-yr Associate degree
 - ___Bachelor's degree
 - ___Master's degree
 - ___Doctoral/Professional degree
-

12. Please indicate your marital status:

- ___single ___married ___widowed ___divorced ___separated
-

13. Which of the following groups best represent your ethnicity?

- ___African American
- ___Hispanic (Latino)
- ___Asian

- _____ Native American (American Indian)
 - _____ European (Caucasian, White)
 - _____ Multi-racial
-

14. Which of the following best represents your annual household income?

- _____ \$0-\$24,999
 - _____ \$25,000-\$49,999
 - _____ \$50,000-\$74,999
 - _____ \$75,000-\$99,999
 - _____ > \$100,000
-

15. What was the purpose of this study?